

Ref #	Part Number	Qty.	Description
1	M0238616	18	SCREW-SM
2	L2099492	1	BRACKET LIGHT SXS 48 FF
3	A3079001	4	LAMP - 40W
4	PE950125	4	LIGHT SOCKET
5	PK930268	1	COVER LIGHT ASM AF AR 30 SXS 48 FF
6	PM910405	6	SHELF WIRE AF 30
7	PM910282	2	LADDER SIDE
8	M0238535	12	SCREW-SM
9	PD950013	6	LATCH PANEL ACCESS
10	K20911929	1	BRACKET ICE SHELF R
11	G50911312	1	MOUNT IM ASM AF 30
12	PC080031	6	SLIDE 12 FULL EXTENSION
13	A4539601	12	SUB TO PC040010 - RIVET-POP VA4539601
14	10270203	2	HOUSING-LIGHT V10270203
15	B5733302	2	CLIP-GROUND
16	G50911176	2	BRKT SIDE GLIDE MOUNT ASM
17	G50911181	2	TRIM ASM SIDE AF 36 30
18	G50911315	2	DRAWER BASKET ASM AF 30
19	G50911316	1	DRAWER ICE ASM AF 30
20	PD020258	9	SCREW, SM
21	PK930346	2	COVER LIGHT
22	G50911931	1	SHELF ICE ASM UPPER AF 30
23	K20911928	1	BRACKET ICE SHELF L
24	PM910285	1	LADDER CENTER

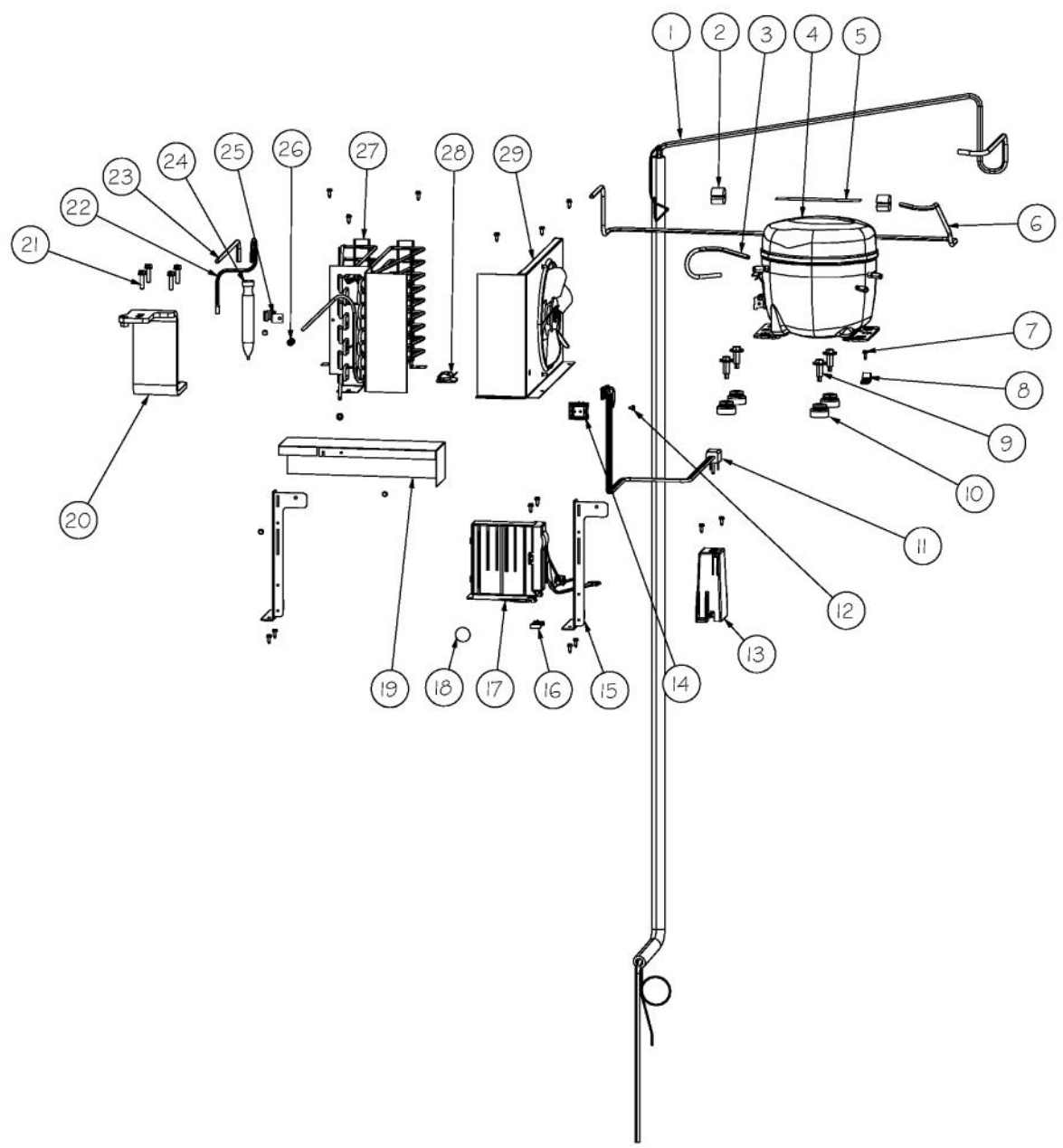

Ref #	Part Number	Qty.	Description
1	F20911307	1	TUBE FORMED HT EXCH AF 30
2	10699601	2	DAMPER-TUBING .8
3	F2096507	1	TUBE-PROCESS GRN
4	PM010619	1	COMPRESSOR VCC
5	C8982701	1	LABEL-COMP WARN
6	F20910729	1	TUBE DISCHARGE FORMED AF AR 36
7	PD020194	18	SCREW-SM
8	PD030118	1	SCREW - SHLDR
9	M0221523	4	SCREW - SHLDR
10	10835901	4	GROMMET RUBBER V10835901
11	10916507C	1	CORD-POWER V10916507
12	M0211014	1	SCREW-SM
13	PE970608	1	POWER SUPPLY 24 VDC 15 W
14	PE950149	1	SWITCH POWER
15	014190-000	2	BRACKET GRILLE SUPPORT
16	M0327801	1	SPLICE TAP
17	002574-000	1	INVERTER COMPRESSOR
18	PF930682	1	LABEL WARNING INVERTER
19	014512-000	1	DIVERTER AIR HI SIDE 36
20	PC920204	1	HINGE ASM UL
21	000570-000	4	HEX SCREW
22	003325-000	1	TUBE DRIER COND.
23	F2097740	1	TUBE PROCESS
24	PM910381	1	DRIER - HIGH SIDE
25	10547001	1	CLIP-DRIER V10547001
26	007407-000	2	RING,LOK, .187 DIA
27	A3189370	1	GASKET-FOAM VA3189370
28	M0104102	1	CLIP-CORD RED
29	G5096494	1	COND. FAN ASSY

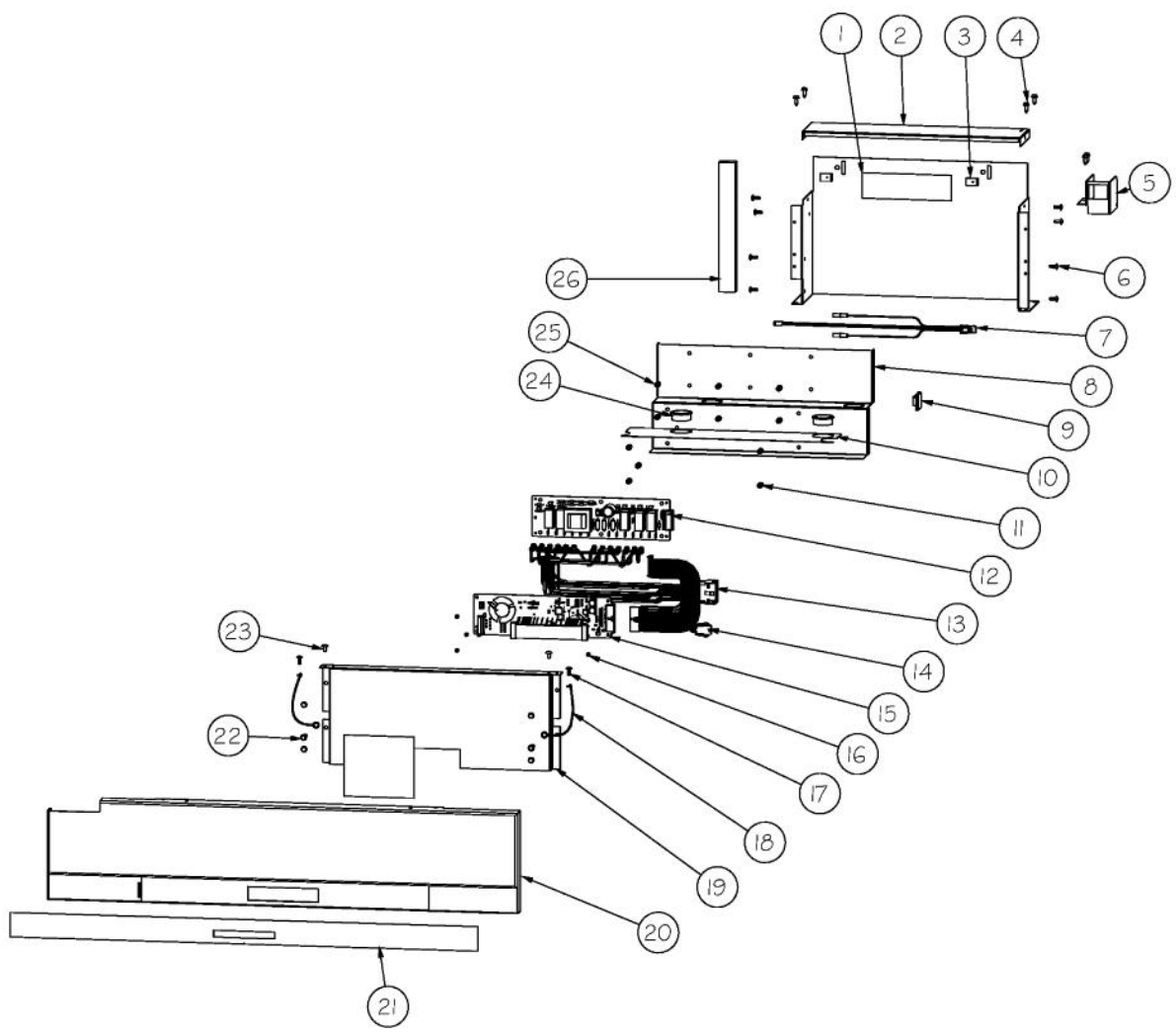

Ref #	Part Number	Qty.	Description
1	PF930487	2	TECH LITERATURE LABEL - 2
2	K20915000	1	CONTROL BOX TOP
3	M0288120	2	NUT-SPEED, VM0288120
4	PD020194	10	SCREW-SM
5	K2098654	1	BRACKET SWITCH POWER
6	PC040010	8	POP RIVET
7	PE970609	1	HARNESS CONTROL BOARD
8	K20910060	1	BRACKET - PC
9	M0104106	1	CLIP-CORD VM0104106
10	005396-000	1	FILM,PROTECTIVE
11	M0585506	5	SUPPORT
12	005319-000	1	POWER CONTROL BOARD ASM
13	PE070785	1	HARNESS HIGH VOLT
14	PE970464	1	HARNESS LOW VOLT
15	PE070728	1	BOARD LOW VOLTAGE
16	PD020013	5	TYPE AB NO.6 X 3/8 PH PAN HD. SMS
17	PC040010	2	POP RIVET
18	12064001	2	SUPP-CONT PANEL
19	K20910061	1	CONTROL BOX FRONT
20	PK930220	1	PANEL COVER CONTROL
21	010500-000	1	OVERLAY SWITCH AF 30
22	M0238846	1	SCREW-SHLDR
23	M0224128	2	SCREW-SM
24	A4554817	2	BUSHING-SNAP VA4554817
25	M0585504	6	SUPPORT
26	A3030361	1	GASKET, RED

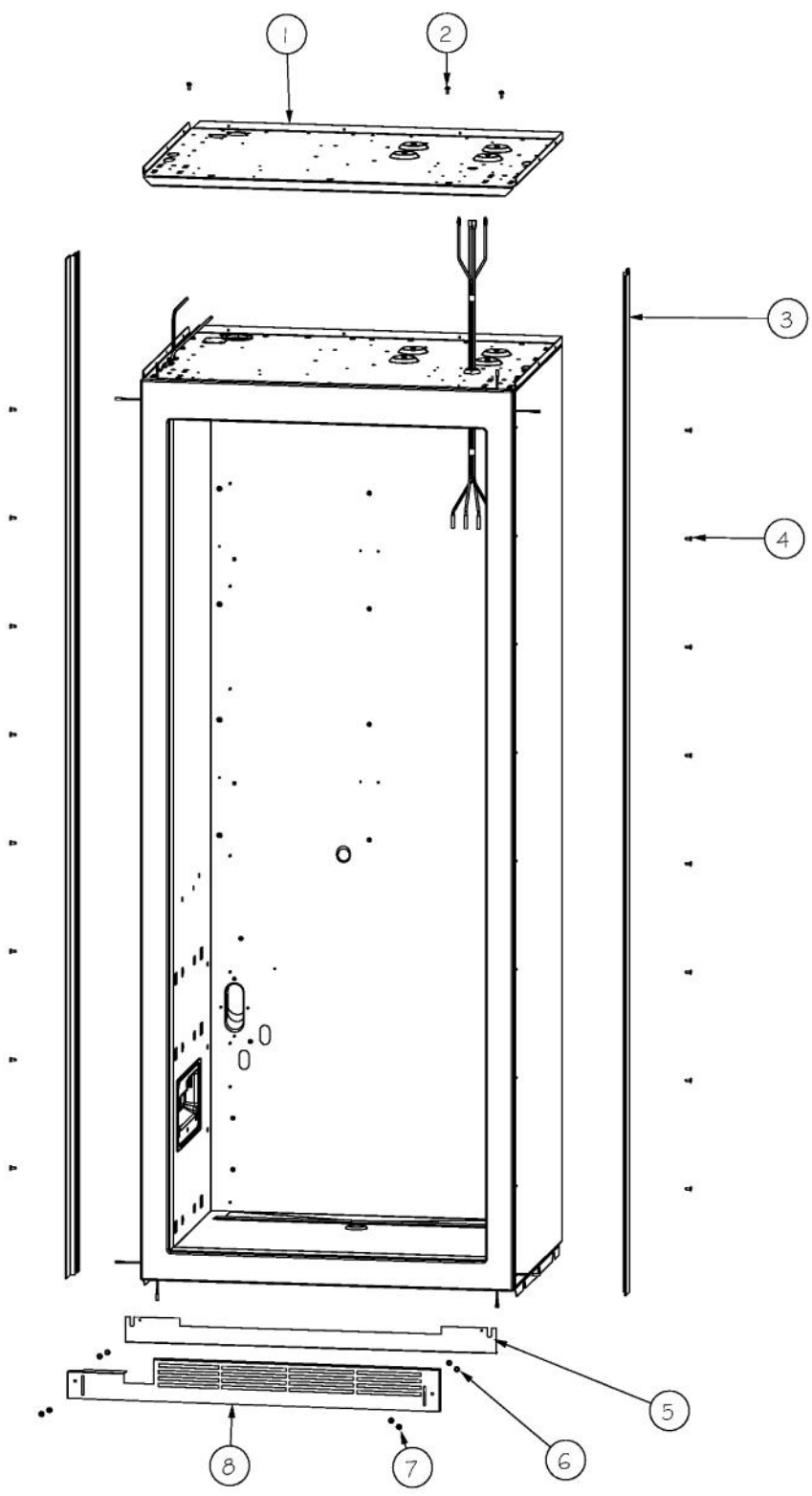

Ref #	Part Number	Qty.	Description
1	K2099037	1	OC TOP AF AR 30
2	PD020010	3	10 X 3/8 GREEN GROUNDING SCREW
3	PK920066	2	SIDE TRIM
4	M0215318	16	SCREW-SM
5	000206-002	1	KICKPLATE, LWR
6	40370P01	4	NYLON FLAT WASHER V40370P01
7	M0210443	4	SCREW-E SM
8	C90910752BK	1	GRILLE TOE VENTED 30 LH BK

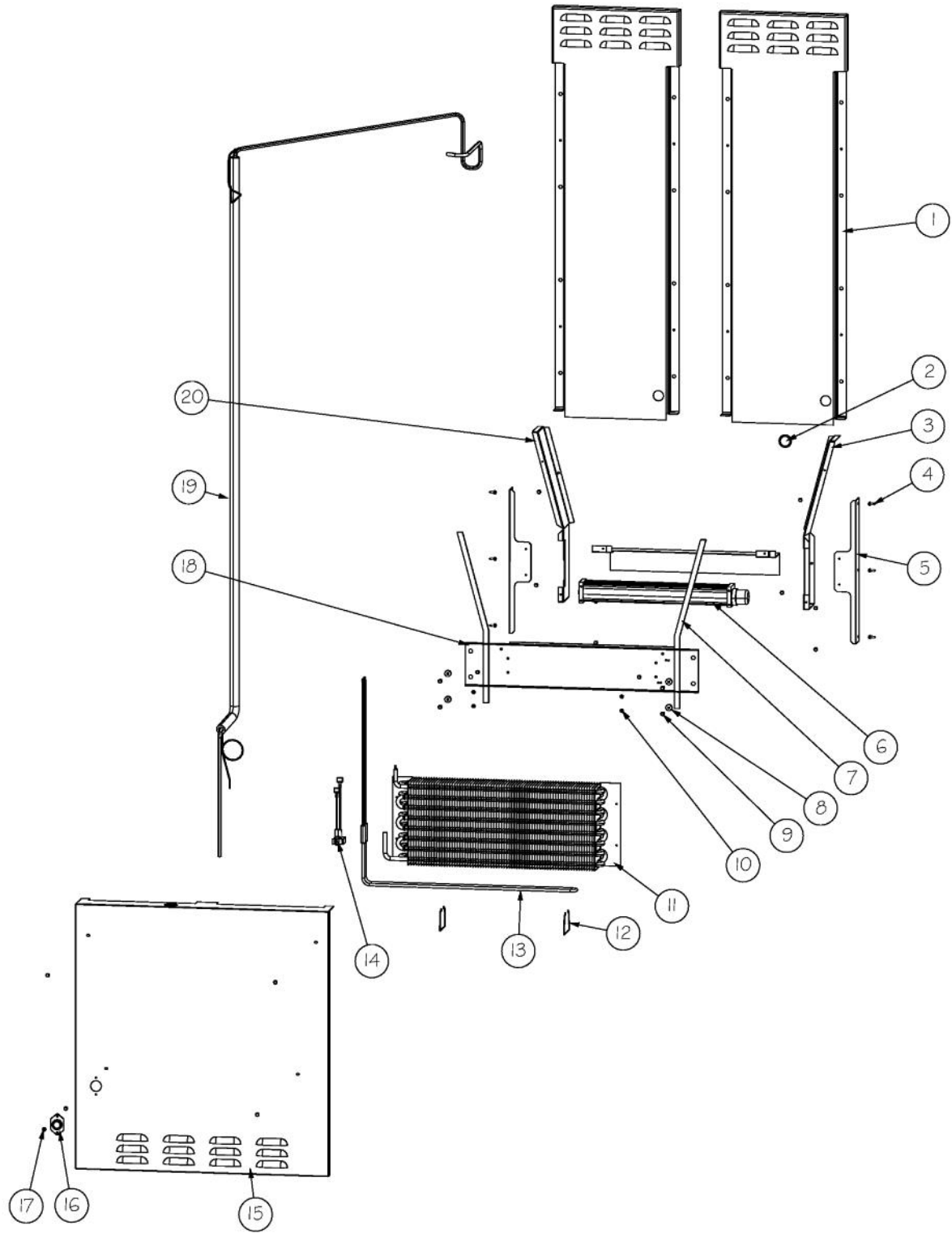

Ref #	Part Number	Qty.	Description
1	L2099055	2	EVAP COVER UPPER AF 30
2	PM910477	1	PLUG HOLE PLASTIC 1.00 DIA.
3	K20912598	1	DIVERter AIR AF 30 R
4	M0238616	19	SCREW-SM
5	K20912558	2	BRACKET EVAP COVER
6	PE950154	1	FAN EVAP HORIZ AF AR 30
7	G50911915	1	COVER EVAP & AIR HANDLING ASM AF 30
8	12234001	4	GROMMET-VIBRATION
9	M0238859	4	SCREW-SHLDR
10	M0218115	4	SCR6-20 BT HXWS 3/8 S
11	PM910456	1	EVAPORATOR AF 30
12	PM910468	2	CLIP EVAP HTR 36 30 AF
13	PJ910038	1	DEFROST HEATER AF 30
14	PB910259	1	THERMOSTAT DEFROST TERMINATOR
15	L20911932	1	COVER EVAP LOWER AF 30
16	C8983701	1	THERMISTOR
17	PD020010	1	10 X 3/8 GREEN GROUNDING SCREW
18	K20912559	1	BRKT FAN EVAP AF 30
19	F20911307	1	TUBE FORMED HT EXCH AF 30
20	K20912597	1	DIVERter AIR AF 30 L

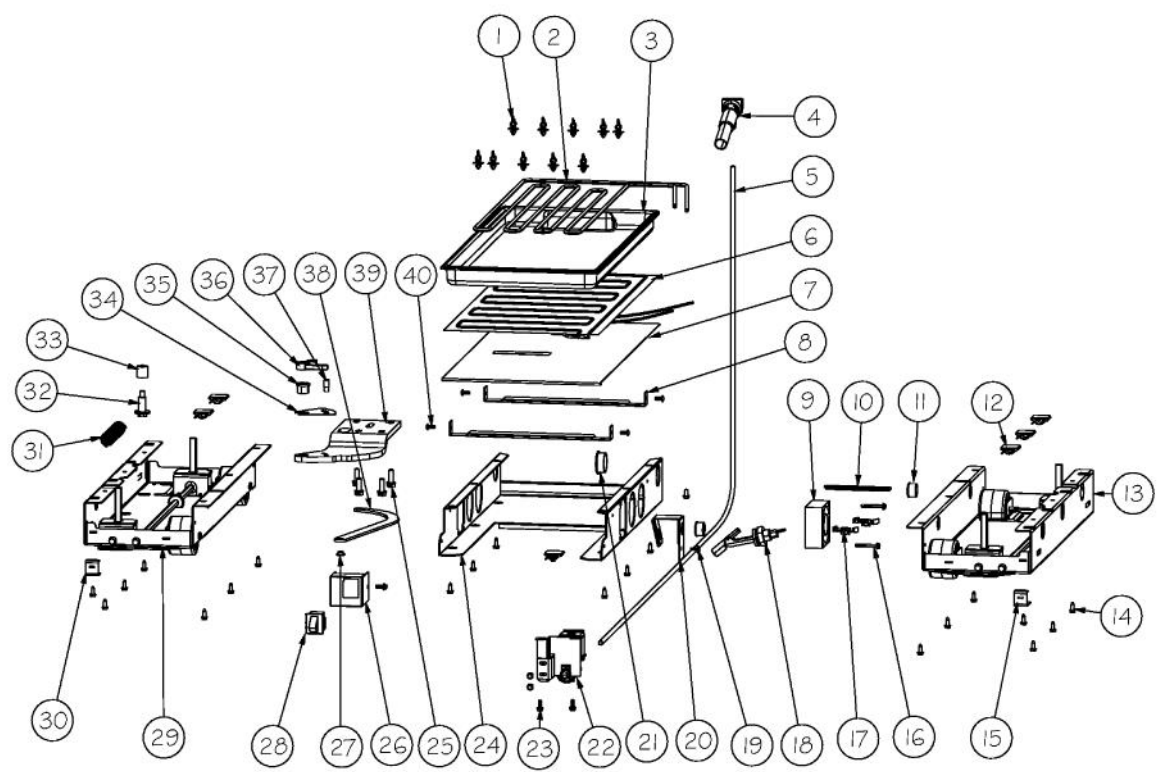

Ref #	Part Number	Qty.	Description
1	PD030146	10	STAND OFF LOCK CLIP
2	F2099927	1	SERPENTINE AF AR 30
3	PK930347	1	PAN-DRAIN AF AR 30
4	10276601	1	ELBOW-FILLER TUBE
5	PB020304	1	PLASTIC TUBING-IM WATERLINE NON DISP (SXS & AF)
6	PE070823	1	PAN HEATER AFAR 30
7	L20915602WH	1	TRAY PAN HEATER AF/AR 30
8	K20911832	2	BRACKET CONDENSATE SUPPORT
9	PE050226	1	MOTOR REF FAN
10	PF930654	1	LABEL CONDENSATE FAN SERVICE
11	A4554806	2	BUSHING-SNAP VA4554806
12	M0104106	6	CLIP-CORD VM0104106
13	PM910398	1	LEVELER ASSEMBLY - R
14	PD020194	20	SCREW-SM
15	K2098044	1	BRKT GRILLE SUPPORT
16	PD020274	1	SCR SLTD HEX WSHR HD 8X1.250 BT
17	M0327801	2	SPLICE TAP
18	PE050248	1	FLOAT SWITCH HORIZONTAL
19	M0253916	1	SCREW-TF
20	B20915627	1	BRACKET HORIZ FLOAT SWITCH
21	A4554817	1	BUSHING-SNAP VA4554817
22	K20913788	1	BRKT VALVE H2O SINGLE
23	M0220417	5	SCREW-TC
24	K20915953	1	SHIELD BOTTOM DRAIN
25	PD940088	4	SCREW, 1/4 X 20 HEX WASHER SERRATED
26	L20915004	1	BASE GRILLE SWITCH MNT LH
27	PD940094	1	BUSHING
28	PE950146	1	SWITCH SPDT BLACK
29	PM910399	1	LEVELER MODULE L
30	K2098096	1	BRKT GRILLE SUPPORT
31	PC910015	1	SPRING EXTENSION
32	M0221523	1	SCREW - SHLDR
33	PD940107	1	ROUND SPRING SPACER
34	PC920144	1	PLATE - WC DOOR SHIM
35	PD940090	1	BUSHING - WC DOOR LEVEL
36	PD940091	1	BUSHING - DOOR STOP
37	PC920145	1	PIN - DOOR STOP
38	PC920149	1	BAR-WC BOT HINGE LH
39	PC920214	1	HINGE PLATE SXS LL
40	PC040010	4	POP RIVET
NI	PK930424	1	VALVE POP UP ASM

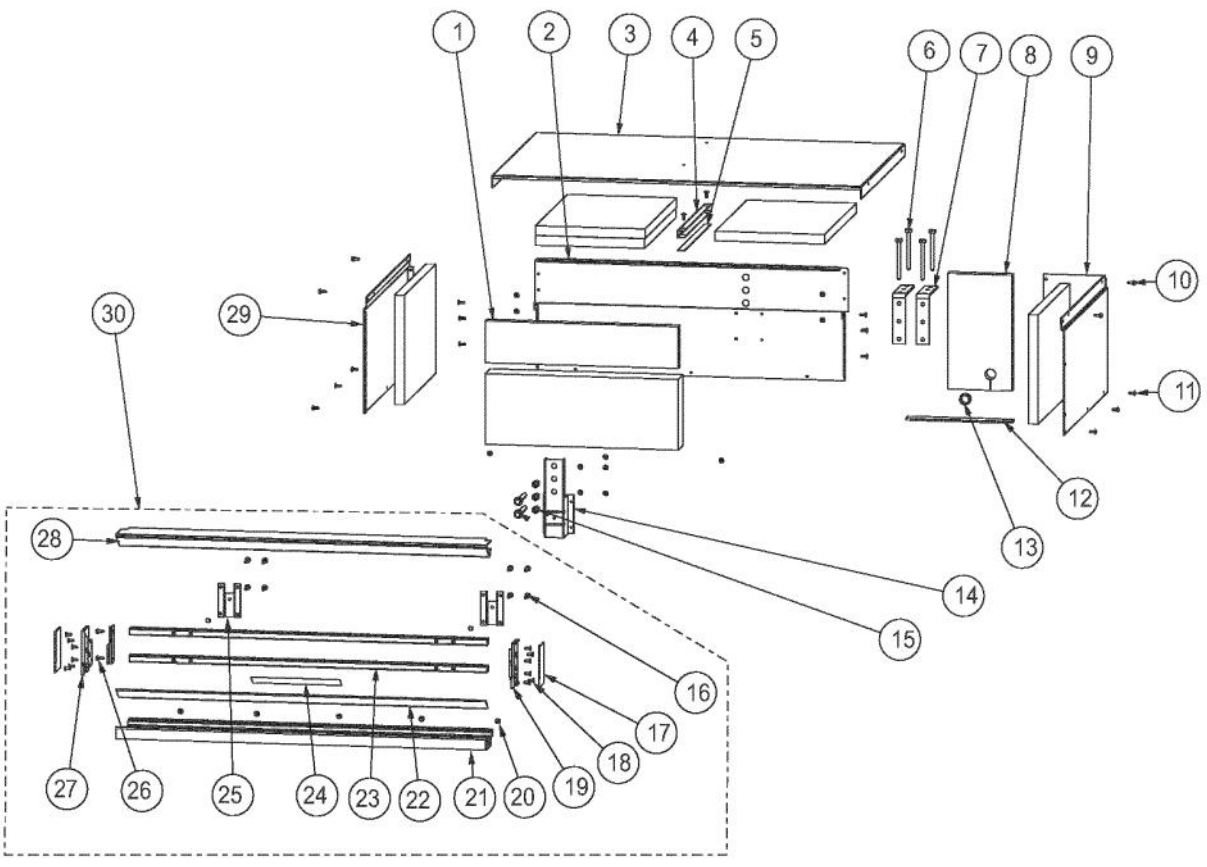

Ref #	Part Number	Qty.	Description
1	PB070356	1	INSULATION MC COVER
2	K2099932	1	MC BACK 30
3	K2099930	1	MC TOP 30
4	K2099455	1	SUPPORT MC Z
5	G5099928	1	MC COVER COMPLETE ASM 30
6	M0223509	4	SCREW-LAG
7	PK910089	2	BRACKET, ANTI - TIP
8	PB970171	1	MC INSULATION - BACK SIDE
9	K2099459	1	MC SIDE R
10	PD020194	30	SCREW-SM
11	PC040010	25	POP RIVET
12	A3189370	1	GASKET-FOAM VA3189370
13	A4554806	1	BUSHING-SNAP VA4554806
14	K20915675	1	BRACKET PSM
15	PD040157	3	BEARING SLEEVE
16	M0213147	8	SCREW-SM
17	PM910072	2	COVER - END CAP 12119802
18	M0215318	12	SCREW-SM
19	PM910348	1	ENP CAP GRILLE R
20	M0224128	1	SCREW-SM
21	PM910408	1	GRILLE LOUVER LOWER AF AR 30 L DES FOL
22	PM910407	1	GRILLE LOUVER MID AF AR 30 DES FOL
23	PM910504	2	GRILLE SPACER 30 FOL
24	PF930523	1	GRILL BLADE LABEL (REFRIGERATOR)
25	PK050004	2	BRACKET GRILLE
26	K2099471	1	BRACKET GRILLE SUPPORT L
27	PM910349	1	END CAP GRILLE L
28	PM910406	1	GRILLE LOUVER UPPER AF AR 30 DES FOL
29	K2099460	1	MC SIDE L
30	019590-000	1	GRILLE ASM, 30 AF/AR FOL LH
30	019606-000	1	GRILLE ASM, 30 AF/AR, FOL RH

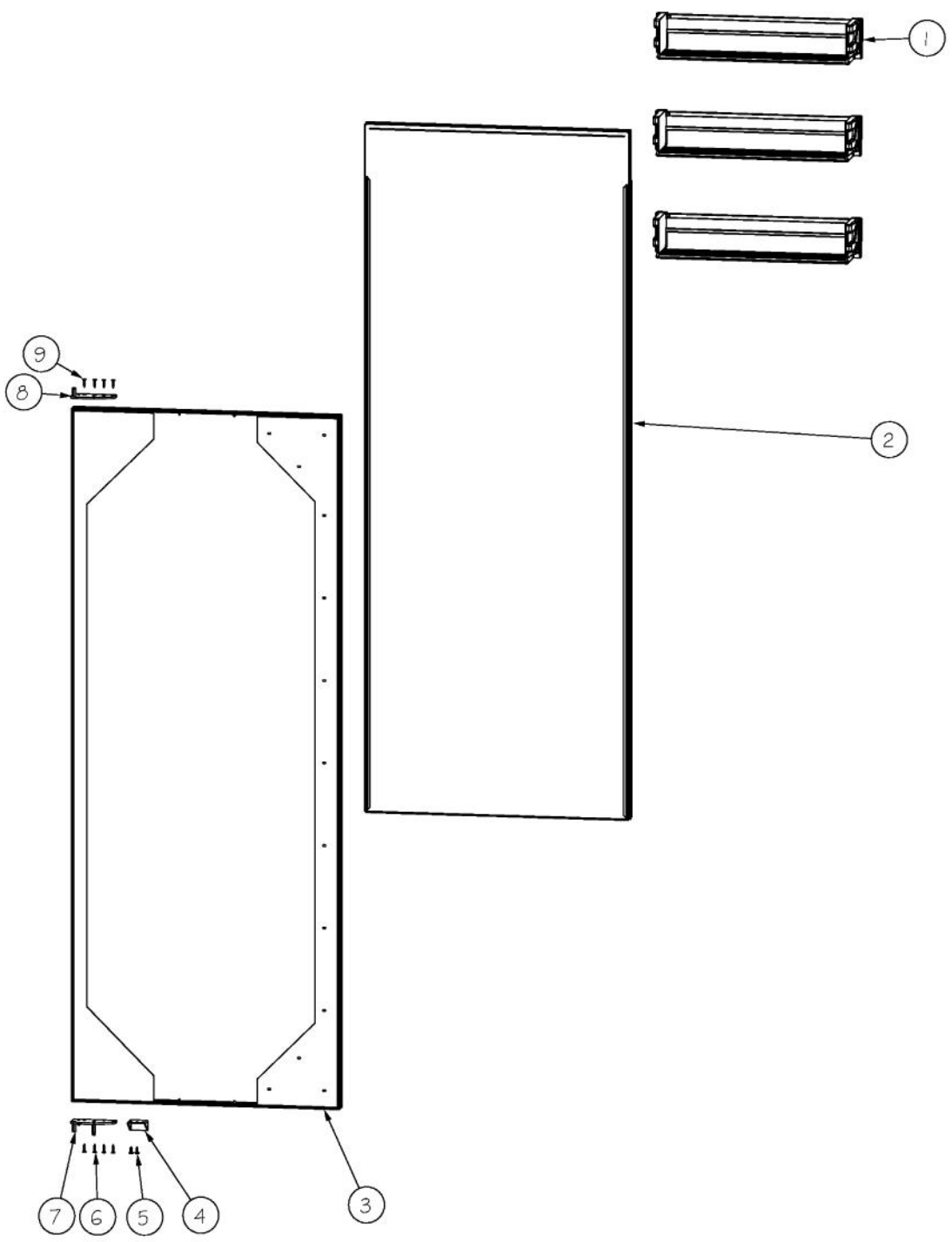

Ref #	Part Number	Qty.	Description
1	G5099904	3	DOORBIN ASM AF 30
2	007450-000	1	DOOR, FOAM, ASM AF 30
3	G3099061	1	PAN WELD ASM AF AR 30
4	PD050019	1	STRIKER DOOR SWITCH
5	M0210458	2	SCREW-SM
6	PD920174	8	10-32 TORX HEAD SCREW
7	PC020273	1	PIVOT PL ASM LH LW FOL
7	PC020277	1	PIVOT PL ASM LH LW PRO/DES
8	PE010030	1	LOGO, 6, PRO, BK
9	PC020275	1	PIVOT PL ASM LH UP FOL
NI	PC020279	1	PIVOT PL ASM LH UP PRO/DES
10	PD020234	1	SCREW THP 10-32 X .500 SS BO
NI	008727-000	1	DOOR ASM COMPLETE AF AR 30 FOL R
NI	008732-000	1	DOOR ASM COMPLETE AF AR 30 FOL RH

*No Image
Available*

Ref #	Part Number	Qty.	Description
NI	044042-000	1	ALL FREEZER FLOAT SWITCH WIRING KIT (FOR UNITS MANUFACTURED BEFORE 1/9/13)