

Ref #	Part Number	Qty.	Description
1	024030-000	1	HANDLE, DOOR, ASM, PRO
2	024027-000	1	SKIN, DOOR, PRO, RH
NI	024036-000	1	SKIN, DOOR, PRO, LH
3	PD010019	4	BLT-1/4-20X3/8HEX WASHER SERATED
4	024031-000	2	DOOR, BRACE, TOP/BOTTOM
5	M0230028	8	SCREW-TC
6	024118-000	2	FASTENER,RIVNUT,8-32 THREAD
7	PD030006	2	CAPPED WASHER PAL NUT
8	PE010016	1	NAMEPLATE, LOGO, PRO
NI	024032-000	1	DOOR, SKIN, ASM, PRO, RH
NI	024037-000	1	DOOR SKIN ASM, PRO, LH

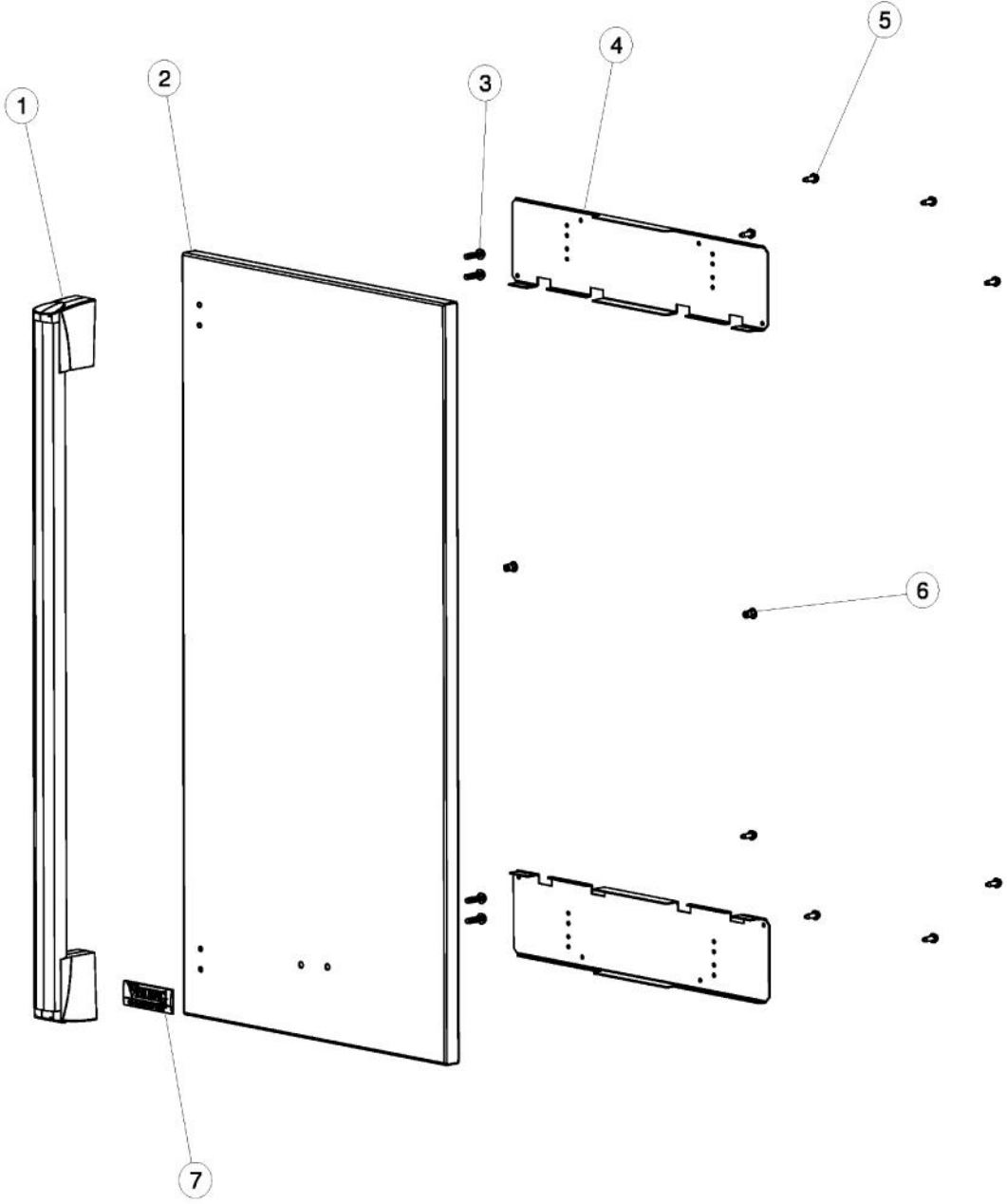

Ref #	Part Number	Qty.	Description
1	009602-000	1	HANDLE, ASM
2	024062-000	1	SKIN, DOOR, DES, RH
NI	024064-000	1	SKIN, DOOR, DES, LH
3	008974-000	4	SCREW 10 - 32 X 3/4 SLOT HEX WASHER
4	024031-000	2	DOOR, BRACE, TOP/BOTTOM
5	023122-000	8	SCR 8-32 SHXW 1/2 TRI-LOBE
6	024118-000	2	FASTENER,RIVNUT,8-32 THREAD
7	013700-000	1	2.75 DESIGNER LOGO WITH PINS
NI	024063-000	1	DOOR SKIN ASM, DES, RH
NI	024065-000	1	DOOR, SKIN, ASM, DES, LH

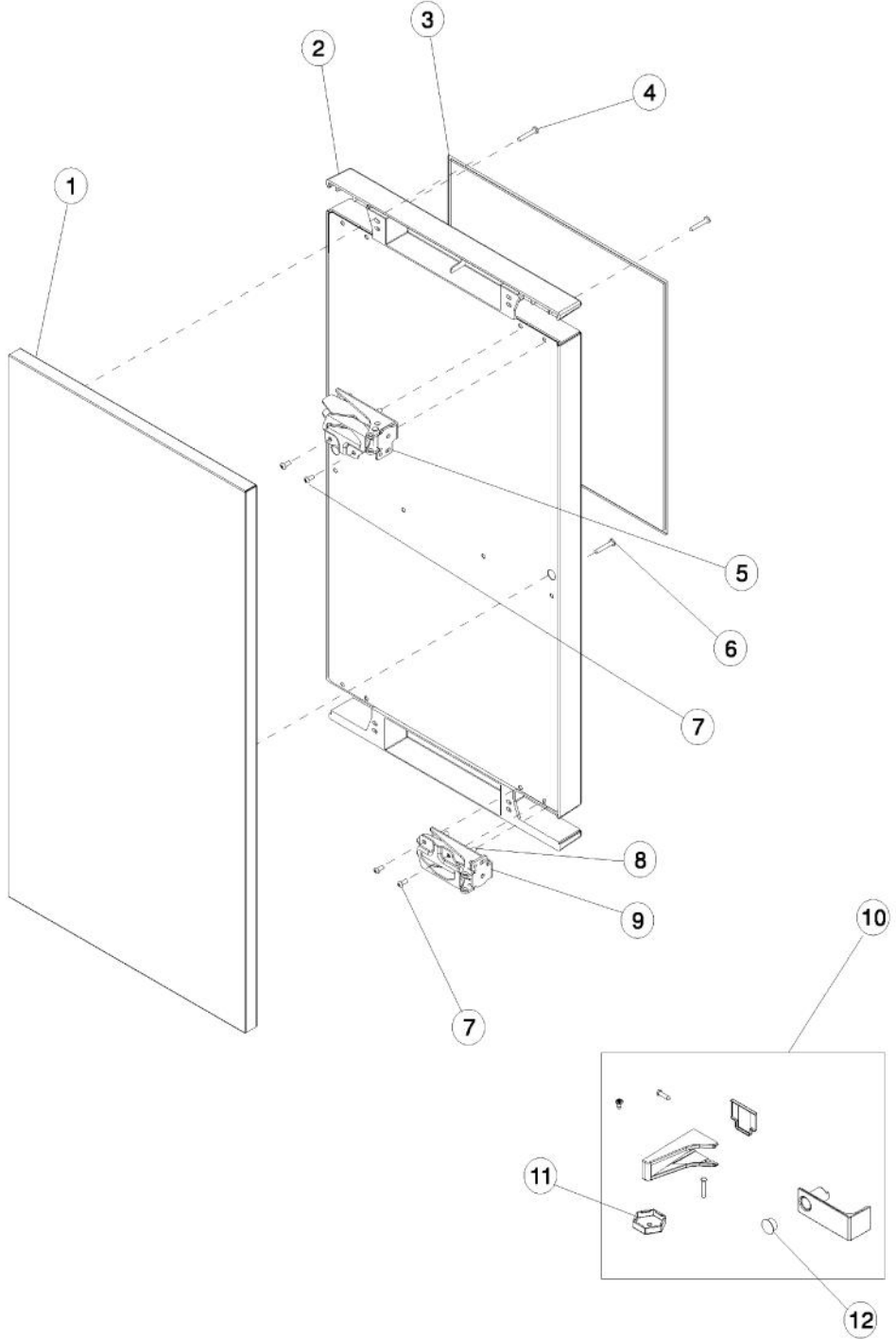

Ref #	Part Number	Qty.	Description
1	024032-000	1	DOOR, SKIN, ASM, PRO, RH
1	024037-000	1	DOOR SKIN ASM, PRO, LH
1	024063-000	1	DOOR SKIN ASM, DES, RH
1	024065-000	1	DOOR, SKIN, ASM, DES, LH
2	022635-000	1	DOOR ASSEMBLY, DOES NOT INCLUDE DOOR PANEL OR H...
3	022633-000	1	DOOR GASKET
4	022629-000	2	SCREW
5	022628-000	1	HINGE-TOP RIGHT/BOTTOM LEFT
6	022631-000	1	SCREW
7	022630-000	4	SCREW-HINGE TO DOOR
8	022632-000	4	SCREW-HINGE TO CABINET
9	022627-000	1	HINGE-TOP LEFT/BOTTOM RIGHT
10	022560-000	1	HINGE COVER PACKAGE/HARDWARE
11	022555-000	1	LEG CAP, PACK OF 4
12	022626-000	1	HOLE PLUG - WHITE
NI	022634-000	1	DOCUMENT PACKAGE

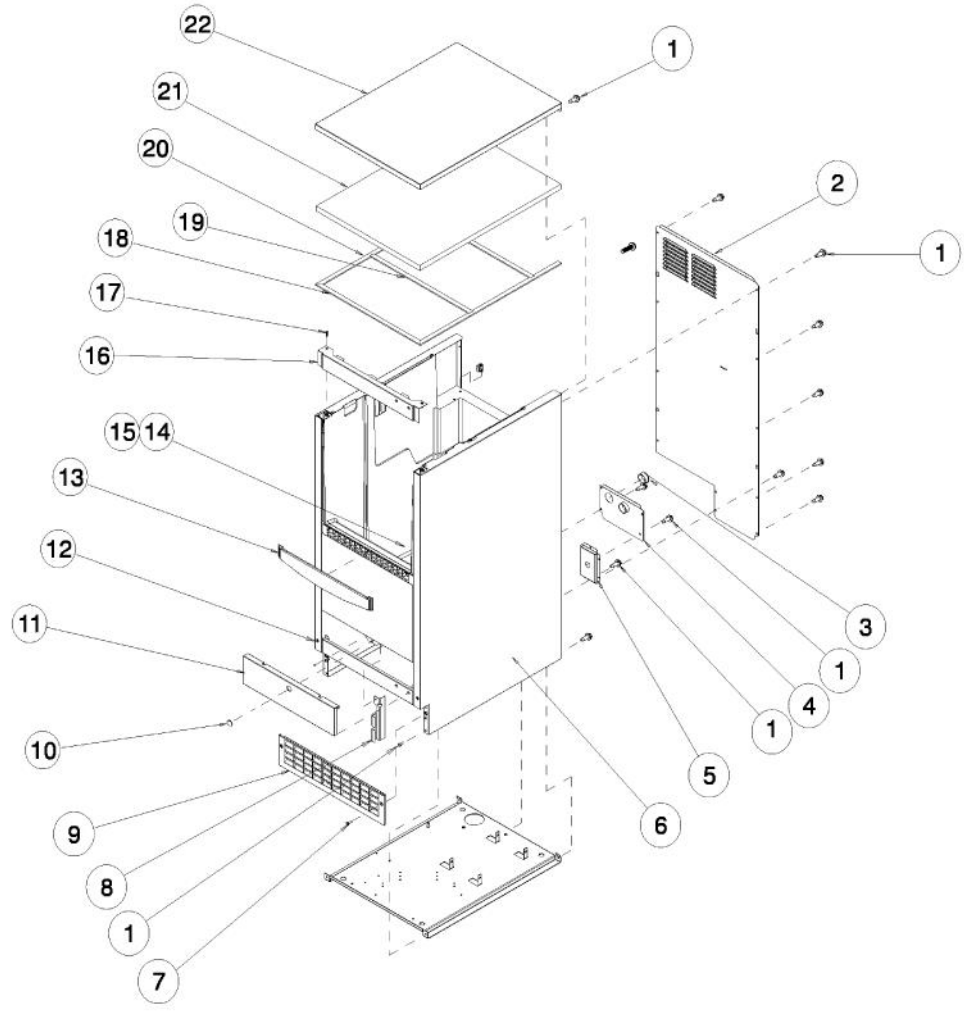

Ref #	Part Number	Qty.	Description
1	022565-000	10	SCREW
2	022610-000	1	BACK PANEL
3	022581-000	1	SNAP BUSHING
4	022617-000	1	UTILITY ROUTING BRACKET
5	022439-000	1	SUCTION LINE ASSEMBLY
6	022614-000	1	CABINET & BIN, SS
7	022563-000	2	SCREW
NI	022567-000	2	SCREW, SS
8	022618-000	1	SRV PANEL MNTG BRACKET
9	022549-000	1	KICKPLATE
NI	022620-000	1	KICKPLATE, SS
10	022525-000	1	HOLE PLUG
11	022625-000	1	SERVICE PANEL, SS
12	022622-000	1	BTM HINGE BRKT, RIGHT SS
NI	022623-000	1	BTM HINGE BRKT, LEFT SS
13	022551-000	1	BIN EDGING
14	022606-000	1	BIN STAT BRACKET/SCOOP HLDR
15	022550-000	1	SCOOP
16	022611-000	1	TOP HINGE BRKT, RH SS
NI	022612-000	1	TOP HINGE BRKT, LH SS
17	022569-000	2	SCREW
18	022597-000	1	FRONT GASKET
19	022599-000	2	MIDDLE GASKET
20	022598-000	2	SIDE GASKET
21	022557-000	1	INSULATION PAD
22	022624-000	1	TOP PANEL, SS

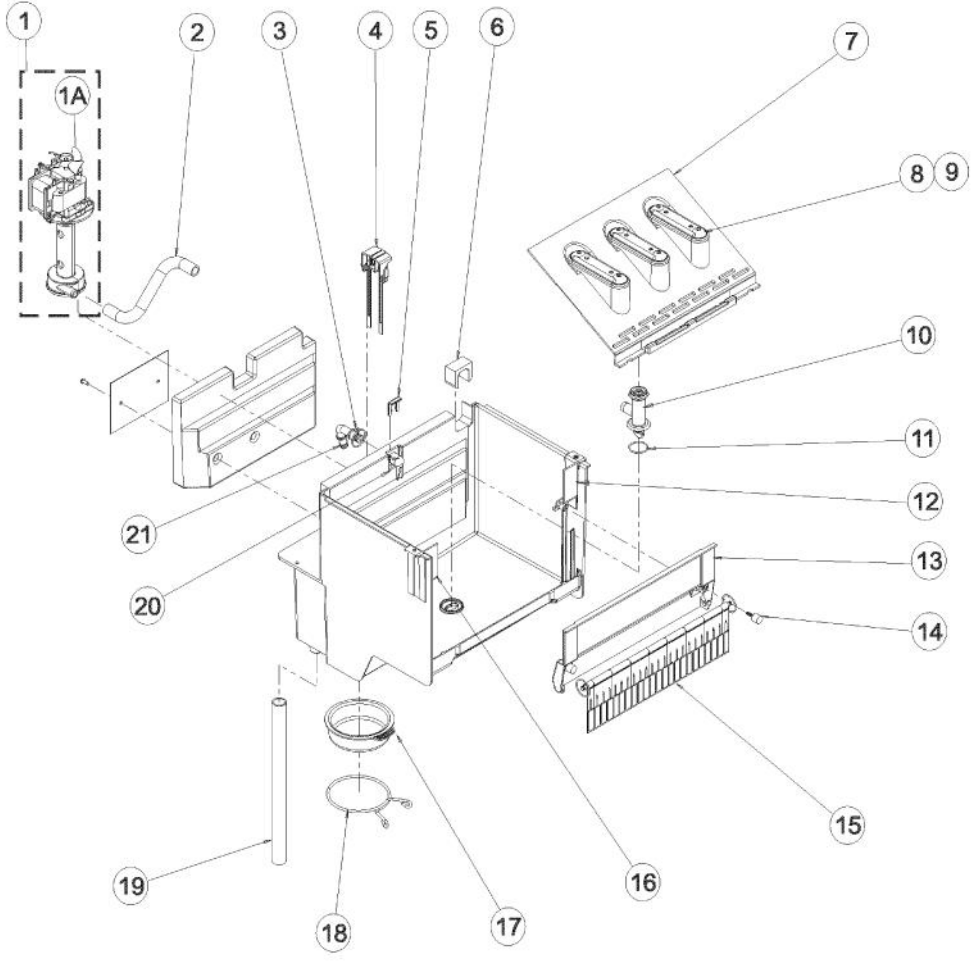

Ref #	Part Number	Qty.	Description
1	022587-000	1	WATER PUMP (INCLUDES FAN BLADE)
1A	031803-000	1	FAN BLADE
2	022541-000	1	PUMP DISCHARGE HOSE
3	022594-000	1	O-RING
4	022608-000	1	WATER PROBE
5	022545-000	1	CLIP
6	022561-000	1	GROMMET
7	022537-000	1	SPRAY PLATFORM
8	022538-000	1	O-RING
9	022536-000	1	SPRAY NOZZLE, KIT. SET OF 4.
10	022534-000	1	WATER TEE
11	022595-000	1	O-RING
12	022539-000	1	EVAP BRACKET, RIGHT
13	022533-000	1	FRONT BRACKET
14	022570-000	2	THUMB SCREW
15	022609-000	1	CURTAIN
16	022573-000	1	EVAP BRACKET, LEFT
17	022535-000	1	DRAIN CAP
18	022547-000	1	CLAMP
19	022558-000	1	DRAIN TUBE
20	022544-000	1	SPOUT
21	022543-000	1	BARBED FITTING

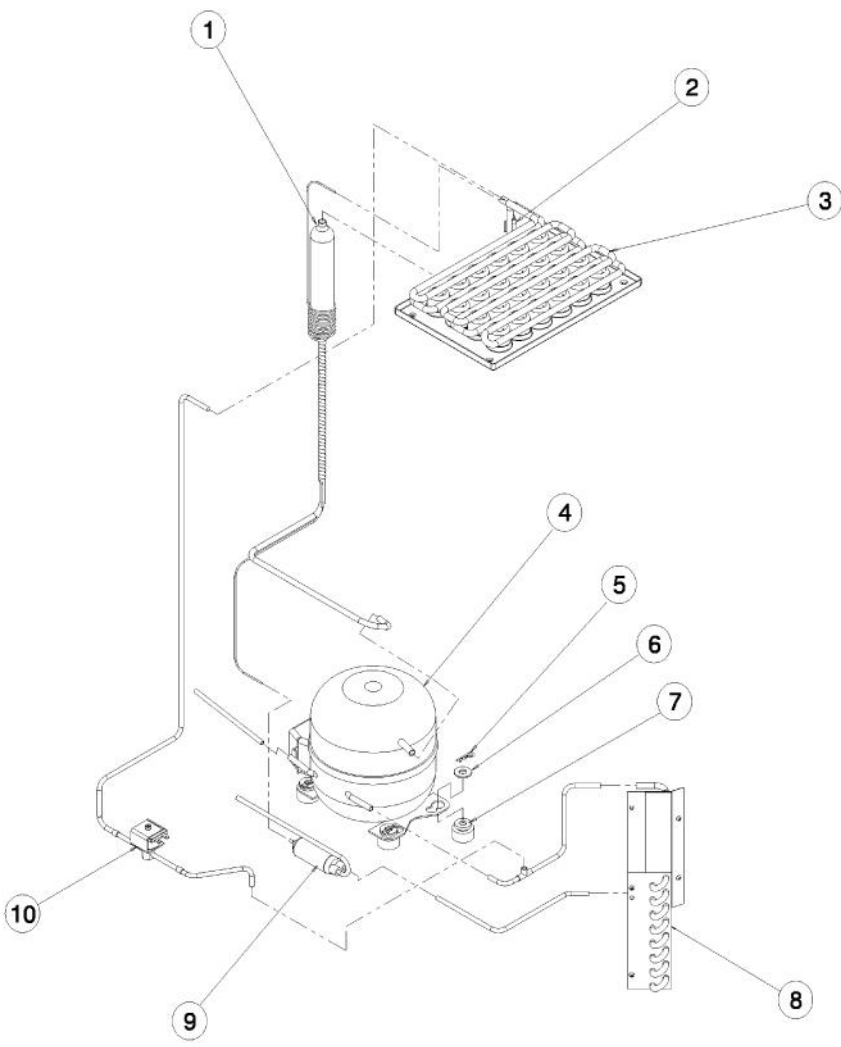

Ref #	Part Number	Qty.	Description
1	022616-000	1	SUCTION LINE ACCUMULATOR ASSY
2	022578-000	1	THERMISTOR
3	022540-000	1	EVAPORATOR
4	022602-000	1	COMPRESSOR (INCLUDES OVERLOAD, RELAY AND DRIER)
NI	022603-000	1	OVERLOAD
NI	022604-000	1	RELAY
5	022568-000	4	CLIP
6	022564-000	4	WASHER
7	022601-000	4	GROMMET
8	022605-000	1	CONDENSER
9	022556-000	1	DRIER
10	022575-000	1	HOT GAS VALVE
NI	022576-000	1	HGV COIL

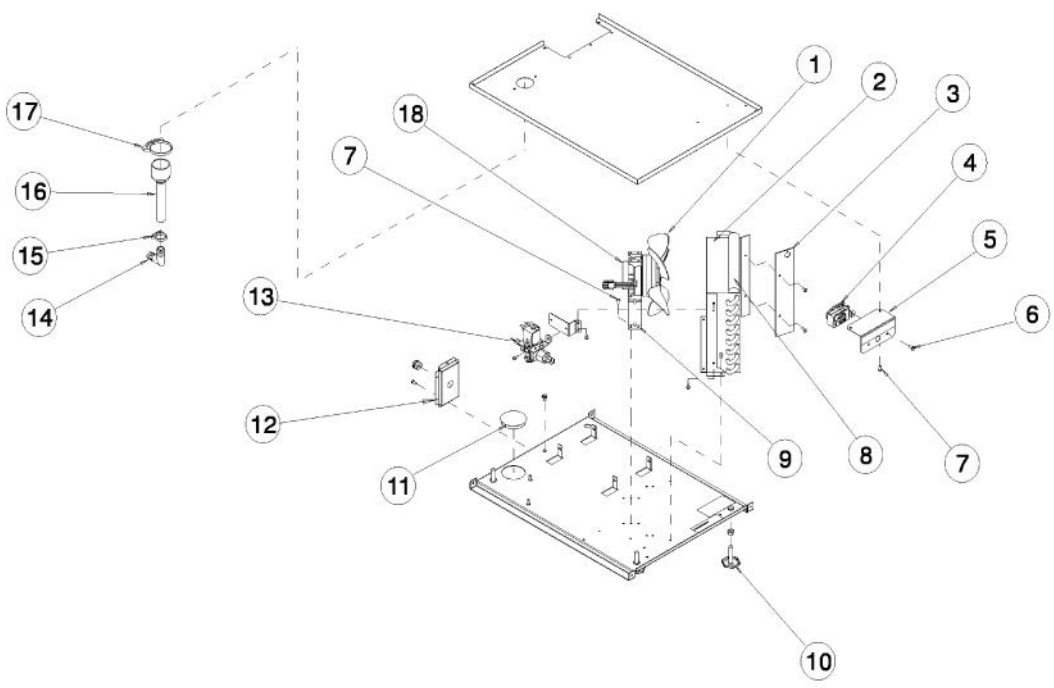

Ref #	Part Number	Qty.	Description
1	022532-000	1	FAN BLADE
2	022619-000	1	FAN SHROUD
3	022559-000	1	AIR BAFFLE
4	022579-000	1	THERMOSTAT
5	022615-000	1	THERMOSTAT BRACKET
6	022562-000	2	SCREW
7	022565-000	2	SCREW
8	022596-000	1	GASKET
9	022621-000	1	FAN MOTOR BRACKET
10	022566-000	4	LEG LEVELER
11	022526-000	1	HOLE PLUG
12	022439-000	1	SUCTION LINE ASSEMBLY
13	022588-000	1	INLET WATER SOL VALVE
14	022600-000	1	ELBOW
15	022527-000	1	HOSE CLAMP
16	022552-000	1	DRAIN HOSE
17	022528-000	1	HOSE CLAMP
18	022593-000	1	FAN MOTOR

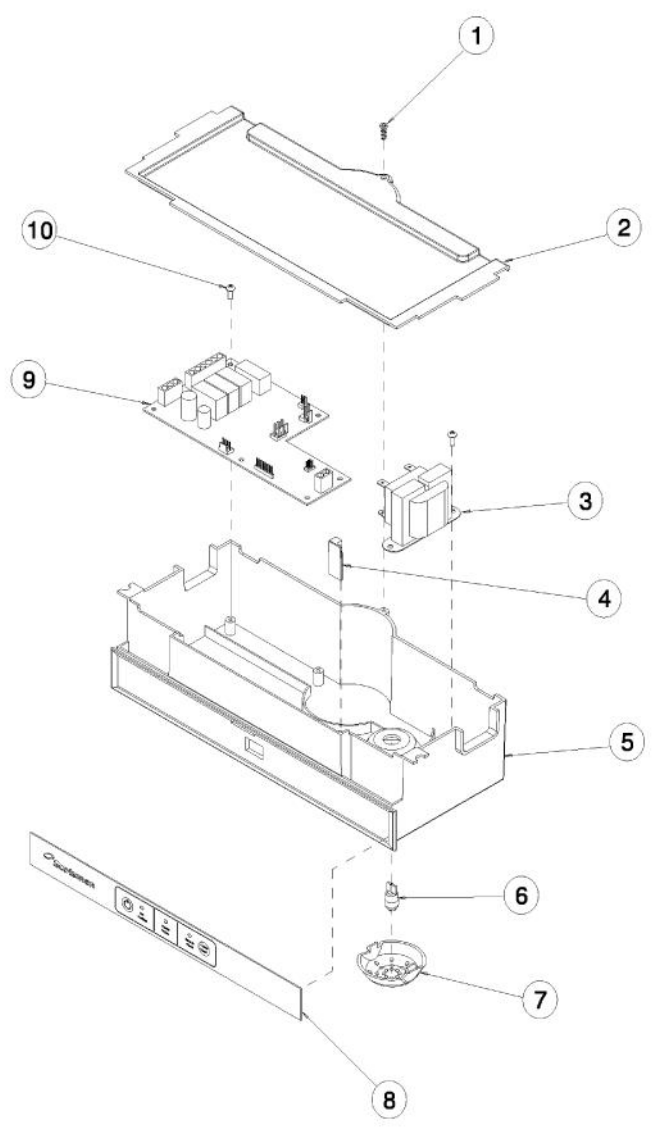

Ref #	Part Number	Qty.	Description
1	022569-000	1	SCREW
2	022548-000	1	COVER
3	022583-000	1	TRANSFORMER
4	022586-000	1	BIN LIGHT SENSOR
5	022546-000	1	CONTROL BOX
6	022584-000	1	BULB
7	022542-000	1	LIGHT COVER
8	022580-000	1	SWITCH PANEL (BEFORE 4/8/14)
8	051857-000	1	MEMBRANE (LIGHT GREY BACKGROUND, WHITE GRAPHIC... (ON OR AFTER 4/8/14)
9	022577-000	1	CONTROLLER
10	022565-000	5	SCREW
NI	022585-000	1	BIN LIGHT HARNESS & SOCKET
NI	022592-000	1	BIN STAT HARNESS
NI	022591-000	1	HI VOLTAGE HARNESS, LOWER
NI	022590-000	1	HI VOLTAGE HARNESS, UPPER
NI	022589-000	1	WATER SENSOR HARNESS

Wiring Diagram

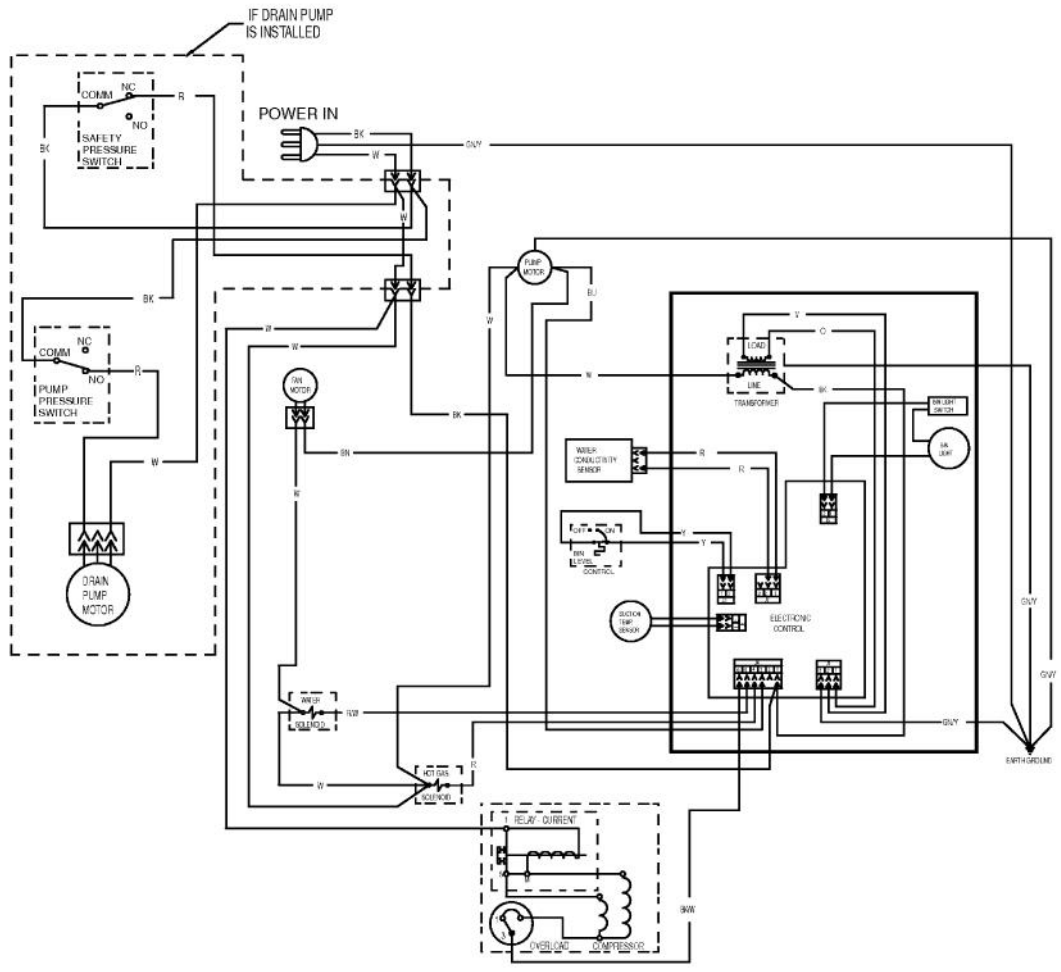

Ref #	Part Number	Qty.	Description
NI	044176-000	1	POWER CORD
NI	044175-000	1	BRACKET, POWER CORD

Schematic Diagram

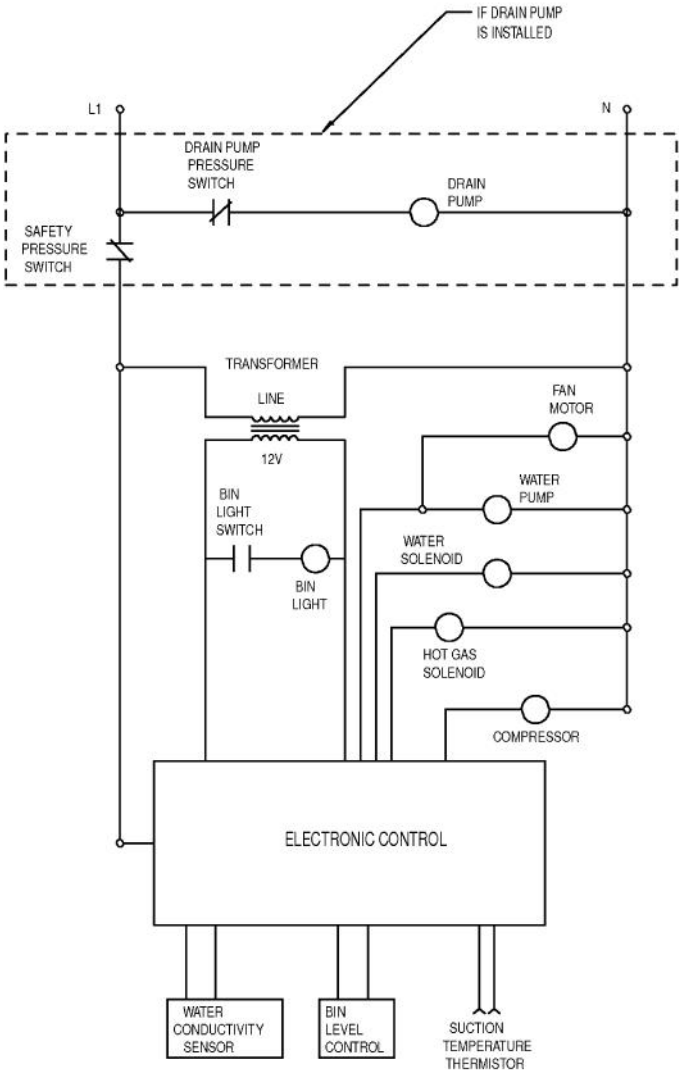

Note:
SWITCHES ON THIS UNIT
SHOWN IN FREEZE CYCLE
WITH DRAIN PUMP IN OPERATION
AND BIN DOOR CLOSED

Ref #	Part Number	Qty.	Description
-------	-------------	------	-------------
