

Ref #	Part Number	Qty.	Description
1	PD030005		SELF RETAINING NUT
2	PD010003		10-24 X 1/2 PH.TR.HD.SERD.M.S.
3	PD020033		SRW-NO.10-24X1/2T(23)PH.WFR HD (NKL)
4	PD020046		NO.8 X 1/2 SCREWS
5	PD020004		10X3/8PH.HD.TYPE 25 REPL PD040125
6	PE010142		3 LOGO XBKXXCHROME
6	PE010143		3 LOGO BK/BR
6	PE010144		3 LOGO XWHXCHROME
6	PE010145		LOGO - WH / BR
7	PD030006		CAPPED WASHER PAL NUT
8	PE050113		DECU INDICATOR LIGHT (SP-2185-BDPS)
9	B30011468		FALSE DRIP TRAY HANLDE (WELDED) - 30
9	G93011458PVD		DRIP TRAY HANDLE ASSY 30 PVD
10	PJ030027		DUAL INFINITE SWITCH REPLACED BY G50013538
11	PB010143		KNOB-DUAL INFINITE SWITCH XBKX
11	PB010144		KNOB-DUAL INFINITE SWITCH XWHX
12	A20011466		FALSE DRIP TRAY HANDLE BRKT. LH
13	A20011467		FALSE DRIP TRAY HANDLE BRKT. RH
14	PE050024		OVEN IND. LIGHT (LIGHT HOUSING)
15	PE070364		POT ASSY - GRAY 28.5 (12-4200)
16	PE070683		POT ASSY- WHITE 33 (12-4500)
17	PE070519		INDUCTION LED ASSEMBLY
18	PA010218		INDUCTION RANGE/RANGETOP KNOB (BK)
18	PA010220		INDUCTION RANGE/RANGETOP KNOB (WH)
19	B92014536		CONTROL PANEL
20	PJ030007		INFINITE SWITCH
21	PB010145		KNOB-SINGLE INFINITE SWITCH XBKX
21	PB010146		KNOB-SINGLE INFINITE SWITCH XWHX
22	PB010208		BEZEL, CHROME PLATE
22	PB010209		BEZEL BRASS
23	G3001406		LANDING LEDGE ASSY
24	A20014514		LED BRACKET
25	PE050023		OVEN IND. LIGHT (LENS & BEZEL)
26	PD020073		SRW NO.10 X 24 X 3/8 WAFER HD TYPE23
27	A20014504		VIRT FRONT SUPPORT

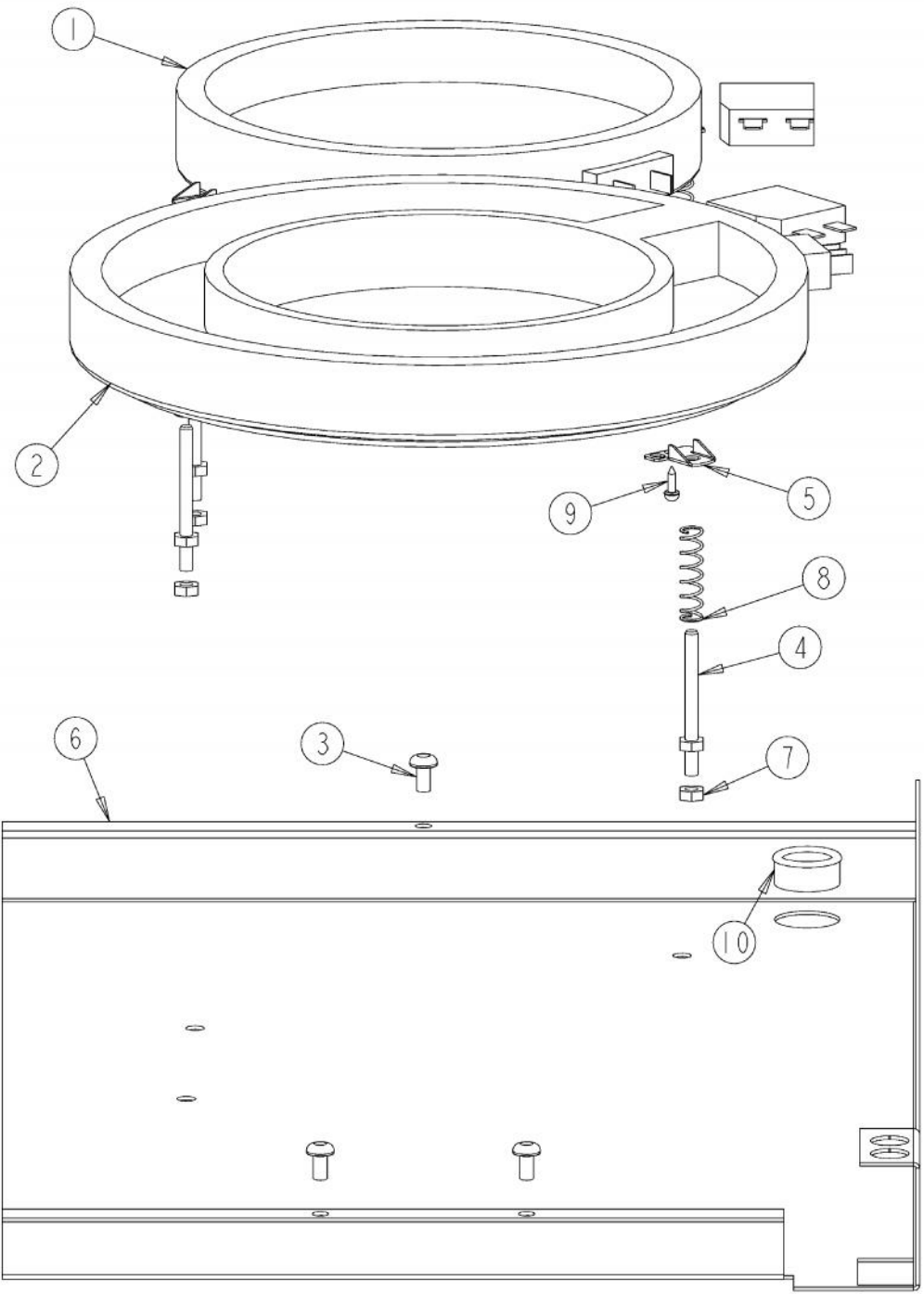

Ref #	Part Number	Qty.	Description
1	PJ020003		ELEMENT
2	PJ020005		2500 ELEMENT
3	PD020004		10X3/8PH.HD.TYPE 25 REPL PD040125
4	PD010148		ELEMENT STUD
5	PM010494		CERAMASPEED BRACKET
6	A20014550		ELEMENT SHELF
7	PD040056		ELEMENT STUD NUT
8	PC010006		GUIDE SPRING DESU
9	PD020013		TYPE AB NO.6 X 3/8 PH PAN HD. SMS
10	PD040005		SNAP BUSHING - 7/8

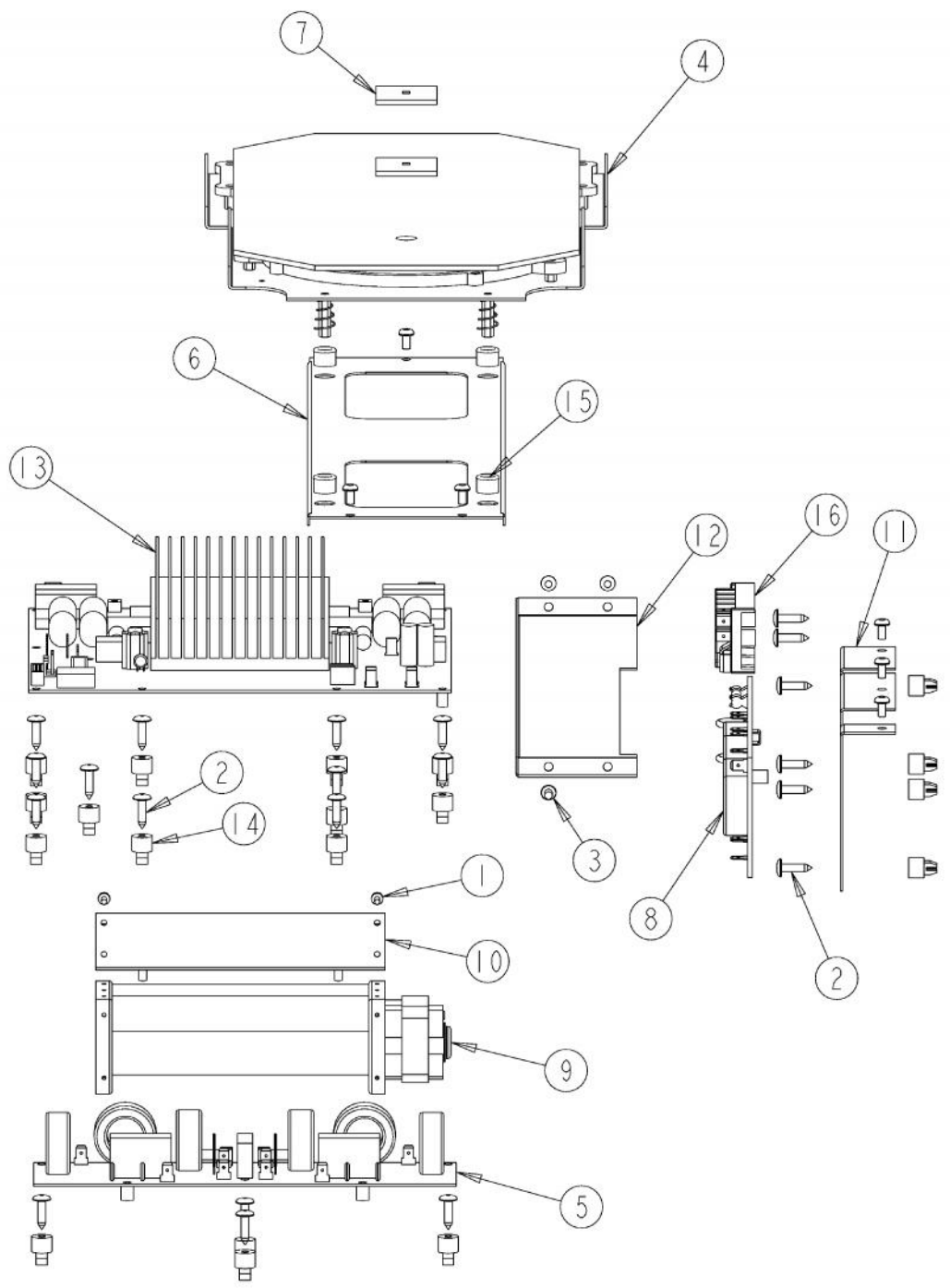

Ref #	Part Number	Qty.	Description
1	PD020067		NO.6 X 3/8 PAN PHIL. TEK SS
2	PD020014		10X3/4 PH TR HD SMS
3	PD020004		10X3/8PH.HD.TYPE 25 REPL PD040125
4	PE070688		ALL INDUCTION COIL TRAY ASSEMBLY
5	PE070597		ALL INDUCTION EMI BOARD
6	A20014510		COIL BRACE
7	PE070761		INDUCTION THERMAL LIMITER
8	PE070627		VICU EMI FILTER
9	PE070635		VICU COOLING FAN
10	A20014512		FAN BRACKET
11	A20014500		POWER BOARD BRACKET
12	A20014520		POWER BOARD COVER
13	PE070596		ALL INDUCTION POWER BOARD
14	PD030033		GROMMET NUT-ROUND HD. NO.8 X .500DIA.
15	PD040021		1/2 BUSHING (VGRC)
16	PE070147		TERMINAL BLOCK

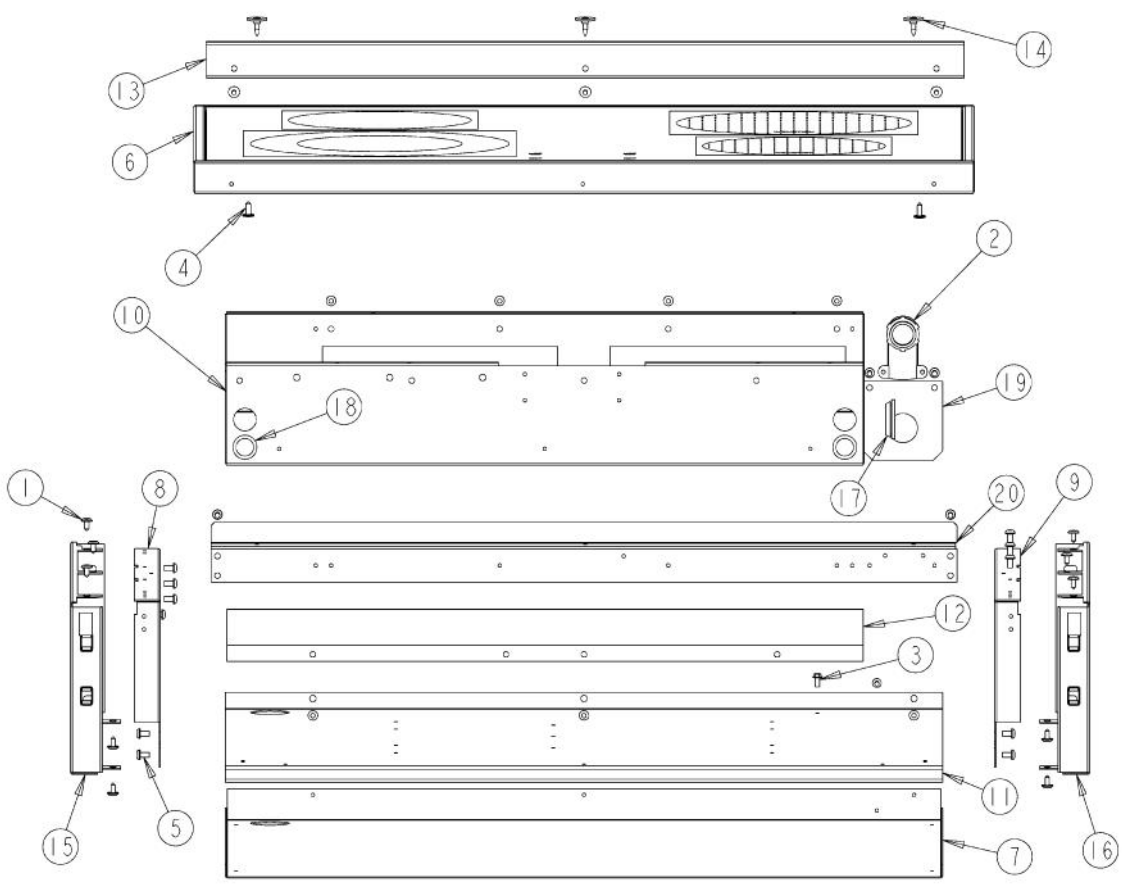

Ref #	Part Number	Qty.	Description
1	PD020032		SRW-8(A)X3/8PH.WFR HD 7/16DIAXNICL
2	PB040259		90 DEG. 3/4 CONDUIT FITTING
3	PD020010		10 X 3/8 GREEN GROUNDING SCREW
4	PD020046		NO.8 X 1/2 SCREWS
5	PD020004		10X3/8PH.HD.TYPE 25 REPL PD040125
6	G50014549		30 VCRT CERAMIC TOP ASSEMBLY (BK)
6	G50014563		MAIN TOP ASSEMBLY - WHITE GLASS
7	A20014518		BURNER BOX BOTTOM
8	A20014502		BURNER BOX SIDE L.H.
9	A20014503		BURNER BOX SIDE R.H.
10	A20014511		COMPONENT SHELF
11	A20014519		INSULATION PANEL
12	A20014515		REAR DIVERTER
13	B2002763		REAR FRAME TRIM (VERT)
14	PD020151		SHOULDER SCREW
15	B20014523		SIDE PANEL - LH
16	B20014522		SIDE PANEL - RH
17	PB070079		SILICONE EXTRUSION (DGSU)
18	PD040005		SNAP BUSHING - 7/8
19	A10014521		VIRT CONDUIT BRACKET
20	A20014507		VIRT REAR SUPPORT

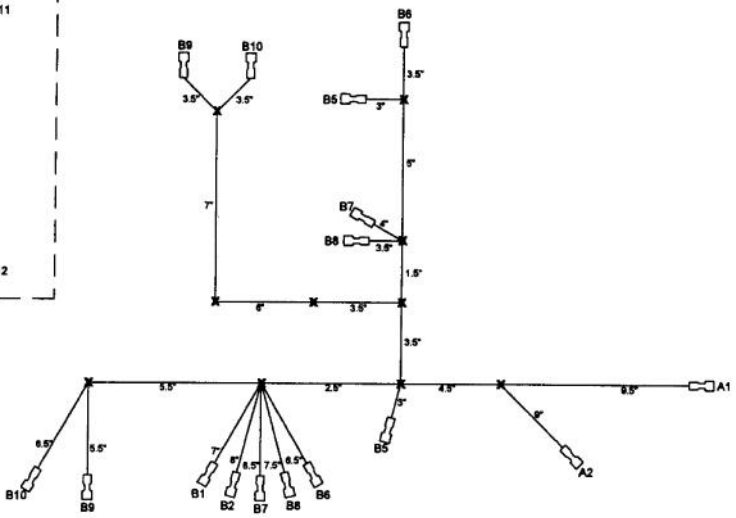
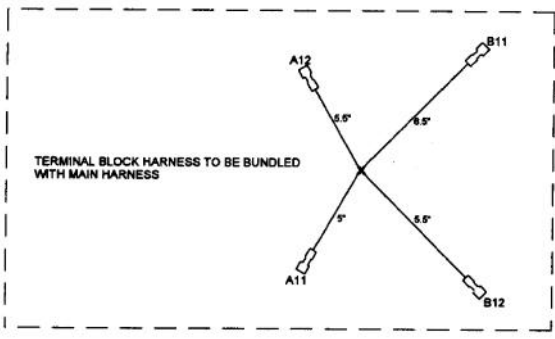

WIRE	COLOR	TEMP	VOLT	DESCRIPTION
1	ORG	105°C	600	J1 TO JE1 (RIGHT SECTION EMI TO POWER CONDITIONER BOARD)
2	BROWN	105°C	600	J2 TO JE2 (RIGHT SECTION EMI TO POWER CONDITIONER BOARD)
3	BLUE	105°C	600	J3 TO JE1 (LEFT SECTION EMI TO POWER CONDITIONER BOARD)
4	WHITE	105°C	600	J4 TO JE2 (LEFT SECTION EMI TO POWER CONDITIONER BOARD)
5	RED	105°C	600	JE3 TO J16 (RIGHT SECTION EMI TO RIGHT SECTION POWER BOARD)
6	BLK	105°C	600	JE4 TO J17 (RIGHT SECTION EMI TO RIGHT SECTION POWER BOARD)
7	VIO	105°C	600	JE5 TO J4 (RIGHT SECTION EMI TO RIGHT SECTION POWER BOARD)
8	GRAY	105°C	600	JE6 TO J5 (RIGHT SECTION EMI TO RIGHT SECTION POWER BOARD)
9	BLK	105°C	600	JE8 TO J18 (RIGHT SECTION EMI TO RIGHT SECTION POWER BOARD)
10	RED	105°C	600	JE7 TO J19 (RIGHT SECTION EMI TO RIGHT SECTION POWER BOARD)
11	RED	105°C	600	L1R TO L2
12	BLK	105°C	600	L2R TO L1

X = WIRE TIE

Ref #	Part Number	Qty.	Description
1	PE070821		INDUCTION WIRE HARNESS

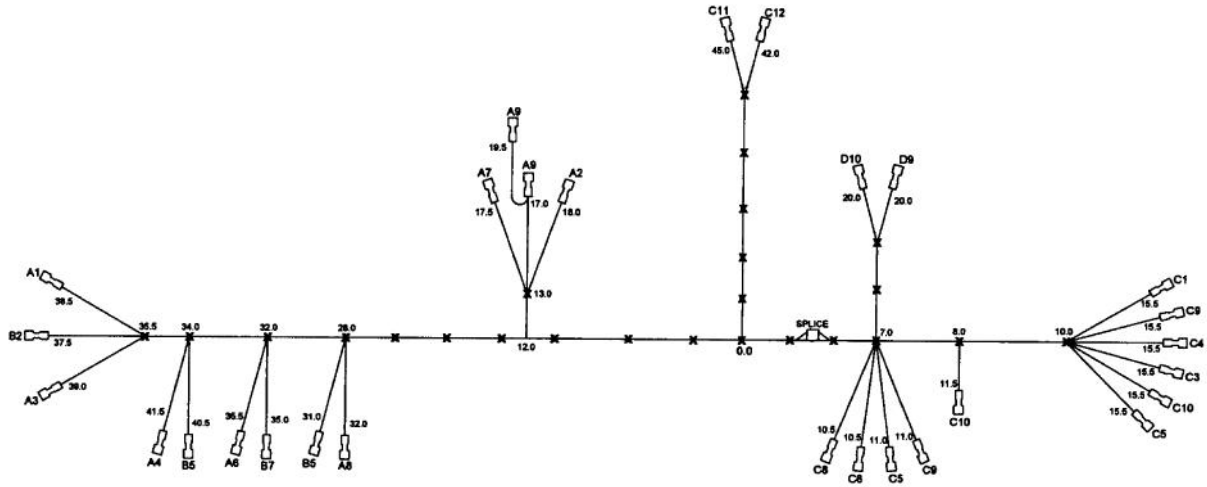

Ref #	Part Number	Qty.	Description
1	PE070822		RADIANT WIRE HARNESS