

Ref #	Part Number	Qty.	Description
1	PA010174		COOKTOP KNOB BLACK
	PA010175		COOKTOP KNOB (WHITE)
	036415-000		KNOB, BODY VGSU CR3
2	PD020076		6-32 X 3/8 PHILL PAN MS
3	PA010179		VESC KNOB MOUNT CORE
4	PB010263		UPPER BEZEL
	PB010263PVD		UPPER BEZEL BRASS (BLACK)
5	PE050187		POWER LIGHT LENS
6	PE050079		LENS OPENING
7	PE010165		VIKING CHROME PLATE LOGO
	PE010166		VIKING LOGO BRASS
	PE010176		2.5 WHITE CHROME LOGO
	PE010177		2.5 WHITE BRASS LOGO
8	PE040252		VECU 36 CONTROL PANEL INLAY
	PE040265		VECU 36 CONTROL PANEL INLAY WHITE GRAPHICS
9	PE040251		36 ELECTRIC CONTROL PANEL
10	PB010262		LOWER BEZEL
11	PD030006		CAPPED WASHER PAL NUT
12	PD030142		SERRATED FLANGE NUT - 5/16NC
13	PE070231		TERMINAL BLOCK - 6 POLE (HEYCO)
14	PD020002		10 X 1/2 PH.TR.HD.SMS.
15	G50013539		PJ030028 INFINITE SWITCH SERVICE KIT
16	PJ030019		INFINITE SWITCH
17	PB070078		SILICONE GASKET (DESU)
18	PD020044		NO.8-32 X 1/4 PH. TR. HD. M.S.
19	G50012147BK		36 VECU TOP ASSY XBKX
	G50012147WH		36 VECU TOP ASSY XWHX

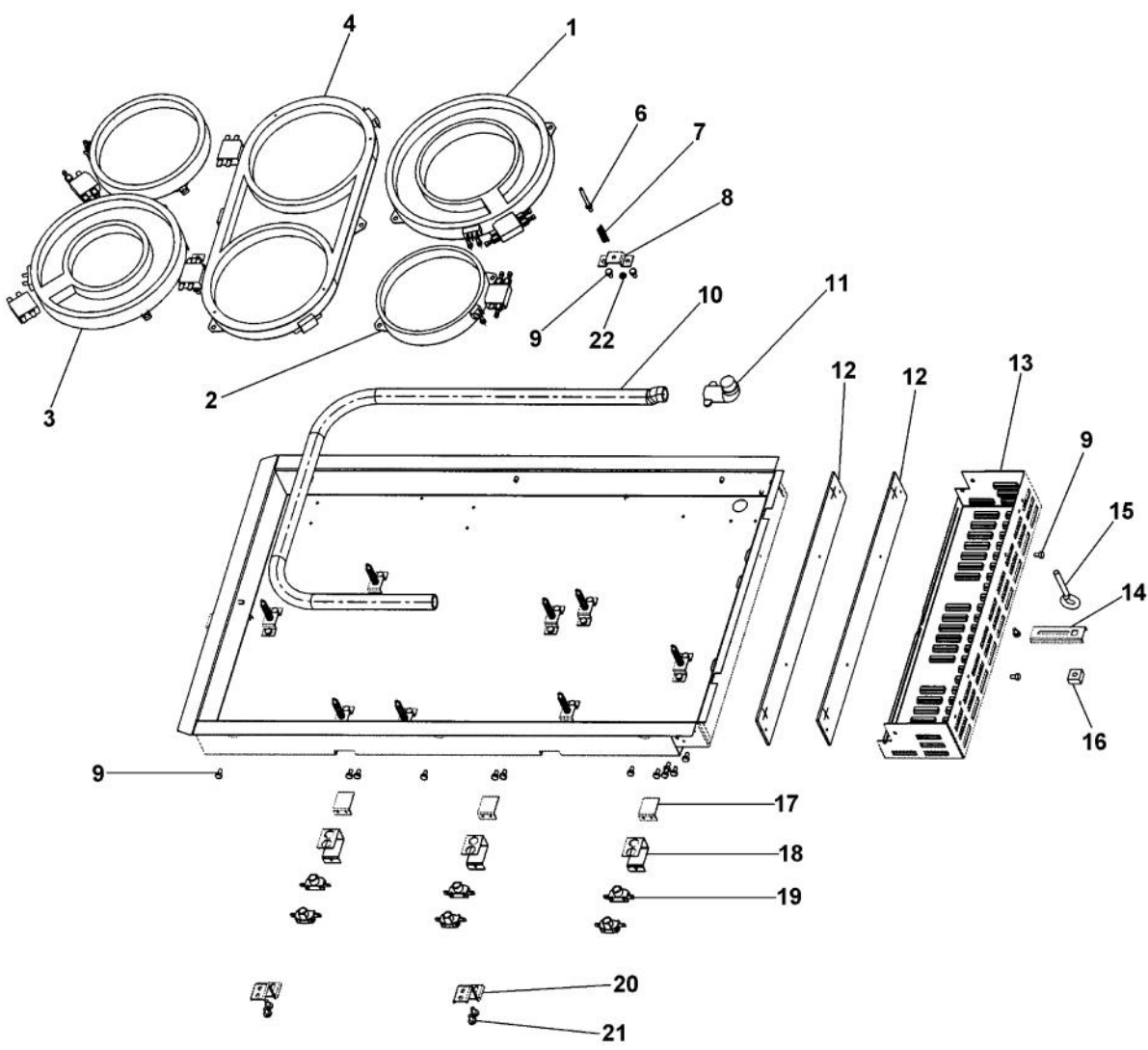

Ref #	Part Number	Qty.	Description
1	PJ020005		2500 ELEMENT
2	PJ020006		1200 ELEMENT
3	PJ020002		ELEMENT 2200 (750)
4	PJ020004		ELEMENT-(2)1800 X 800
5	PJ020003		ELEMENT
6	PD010048		BURNER GUIDE ASSEMBLY DESU
7	PC010006		GUIDE SPRING DESU
8	A2005055		BOTTOM ELEMENT BRACKET (VESU)
9	PD020004		10X3/8PH.HD.TYPE 25 REPL PD040125
10	PB020071		CONDUIT - FLEXIBLE (48)
11	PB040070		CONDUIT FITTING (90 DEG)
12	PB070232		FOIL BACK INSULATION
13	A2005056		CONTROL PANEL BOX
14	A2003053		RET.BRKT VGUSU101 REPL PG210006
15	PD010027		EYE BOLT-VGSU101/161
16	PD030029		SELF RETAINING NUT (1/4-20)
17	A2005062		LIGHT SUPPORT
18	A2005061		LIGHT COVER
19	PE050077		INDICATOR LIGHT
20	A2105068		MOUNTING BRACKET
21	PD020002		10 X 1/2 PH.TR.HD.SMS.
22	PD040056		ELEMENT STUD NUT
NI	PE070644		VECU166 WIRE HARNESS
NI	G4003016		GREEN - SUPPLY WIRE
NI	PE070563		BKX WIRE (8 GA. SF-2 200DEG.C600V)
NI	PE070562		RED WIRE (8 GA. SF-2 200 DEG.C 600V)