

# STONE PROFILES OUTDOOR LIVING

OUTDOOR SOLUTIONS



all  parts.com

1 888 988 4546

# WHAT IS FINISHED?

Finished islands include a choice of KEYSTONE or RIVERSTONE (Stacked Stone) resin stone veneers and a choice of GIALLO or UBA TUBA granite countertops. Install your Viking appliances, plug in the island, hook up the gas, and start grilling.



RIVERSTONE with the UBA TUBA granite top is the most popular.



\* To complete the model number, add the finish and granite selection to the end of the number.

**Example:** OMI-084-01-VKSD

## FINISH

K = Keystone



S = Riverstone (Stacked Stone)



## GRANITE

L = Giallo (Light)



D = Uba Tuba (Dark)



# WHAT IS NAKED?

The “Naked” unfinished islands of recycled aluminum substrate easily accommodate a fast and simple application of custom finishes.

This GREEN building material is light-weight, fire-proof, water proof, vapor proof and exceeds the life of alternative products such as wood and steel.

A unique and different alternative to current pre-fab/ custom islands that are constructed of steel studs, galvanized steel siding, textured paints, pressure treated wood which can warp or hardiboard siding which can split and deteriorate over time.



These lightweight islands can be moved using a dolly, and can be set, leveled, “rocked-in” and completed with a custom finish in one day!



These islands are an ideal solution for projects of Landscapers, Hardscapers, Custom Builders or the “Do-It-Yourself” customers.

Each island product is designed and pre-fitted to seamlessly accommodate Viking outdoor products.



Outdoor Islands

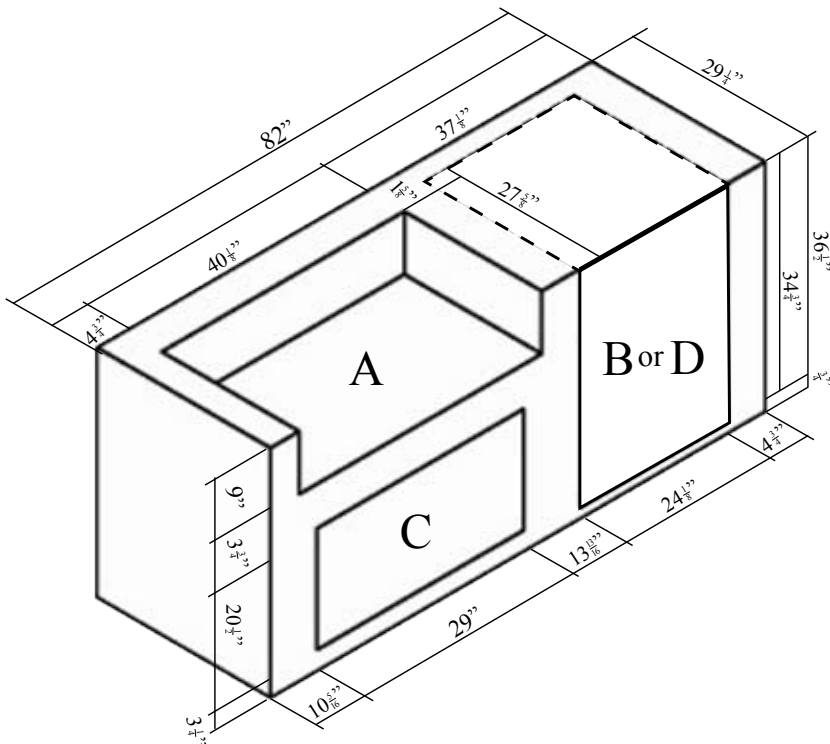

**84" Viking Island/Outdoor Solutions**

- Commercial-type construction, design and styling
- Island is constructed completely of 100% recycled aluminum panels
- Includes UL approved electrical box
- Interior cavity, seams, and corners completely finished in access door section
- Granite countertop / Options: Uba Tuba & Giallo
- Urethane resin veneer / Options: Riverstone & Keystone
- Compatible with all respective "islands plus" islands
- 84"W x 32"D x 37-3/4"H (OA) Footprint
- For use with any Viking 41"W outdoor T-series or E-series grill
- Poly Shims included for leveling

- A. 41" Viking Grill
- B. VUAR143T or VURI140T (R/L) or VURD144T
- C. AD2820T
- D. VUBD140T (R/L)

Field Requirement: MOUNTING OF DISPENSING TOWER AND FLANGED DRAIN PAN ARE NOT INCLUDED.

Model	Finish		Retail Price	Shipping wt. lb
<b>OMI084VK01SD</b>	Riverstone Dark		\$3,899	390
<b>OMI084VK01SL</b>	Riverstone Light		\$3,899	390
<b>OMI084VK01KD</b>	Keystone Dark		\$3,899	390
<b>OMI084VK01KL</b>	Keystone Light		\$3,899	390
<b>OMI084VK01UF</b>	Unfinished		\$2,200	245
<b>OMI084COVER</b>	Black		\$299	5

S = Riverstone    K = Keystone    D = Uba Tuba    L = Giallo    UF = Unfinished

For Specific Use with Viking Outdoor Appliances  
 Island must be vented according to local codes.  
 Please refer to Limited 5 Year Warranty for details.  
 Refrigerator legs are removed for proper installation.

Outdoor Islands

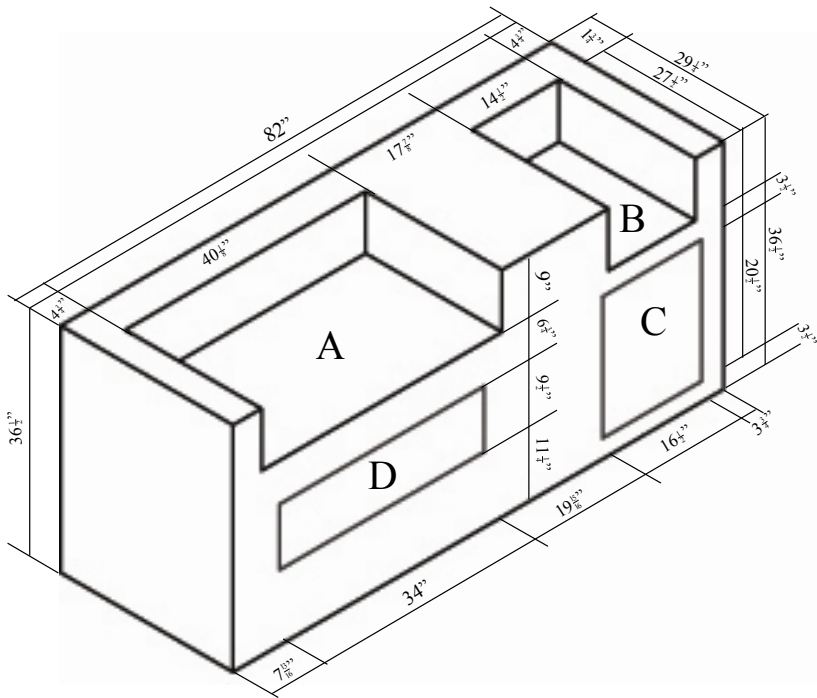

**84" Viking Island/Outdoor Solutions**

- Commercial-type construction, design and styling
- Island is constructed completely of Hardboard and DuraRock material over 20 gauge galvanized studs
- Interior cavity, seams, and corners completely finished in access door section
- Granite countertop / Options: Uba Tuba & Giallo
- Urethane resin veneer / Options: Riverstone & Keystone
- Compatible with all respective "islands plus" islands
- 84"W x 32"D x 37-3/4"H (OA) Footprint
- For use with any Viking 41"W outdoor T-series or E-series grill
- Poly Shims included for leveling

- A. 41" Viking Grill
- B. VGSB152T or VGIB151T
- C. AD1620T
- D. Optional VEWD163T

Model	Finish	Retail Price	Shipping wt. lb
<b>OMI08402VKSD</b>	Riverstone Dark	\$3,899	390
<b>OMI08402VKSL</b>	Riverstone Light	\$3,899	390
<b>OMI08402VKKD</b>	Keystone Dark	\$3,899	390
<b>OMI08402VKKL</b>	Keystone Light	\$3,899	390
<b>OMI08402VKUF</b>	Unfinished	\$2,200	245
<b>OMI084COVER</b>	Black	\$299	5

S = Riverstone    K = Keystone    D = Uba Tuba    L = Giallo    UF = Unfinished

For Specific Use with Viking Outdoor Appliances  
 Island must be vented according to local codes.  
 Please refer to Limited 5 Year Warranty for details.

Outdoor Islands

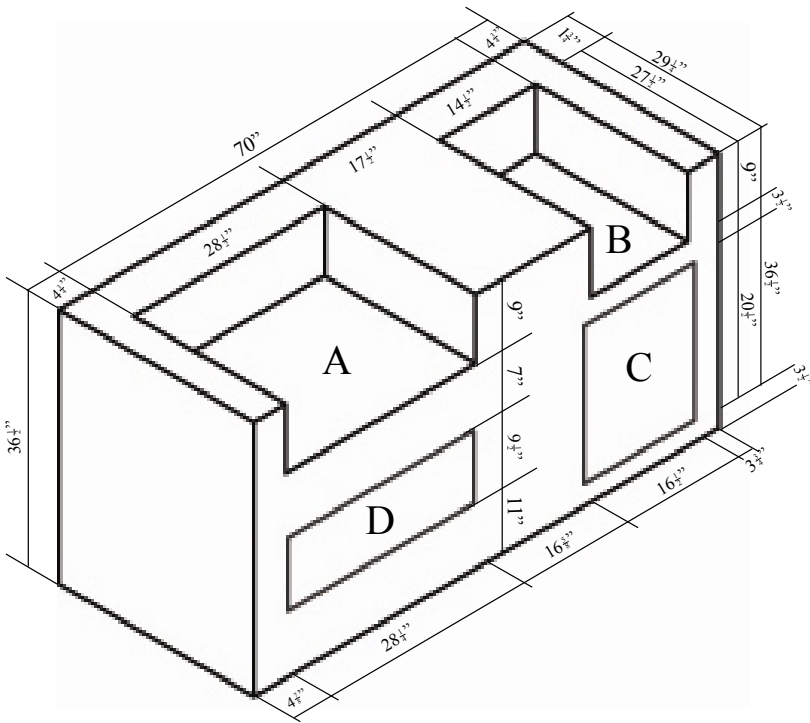

**72" Viking Island/Outdoor Solutions**

- Commercial-type construction, design and styling
- Island is constructed completely of Hardiboard and DuraRock material over 20 gauge galvanized studs
- Interior cavity, seams, and corners completely finished in access door section
- Granite countertop / Options: Uba Tuba & Giallo
- Urethane resin veneer / Options: Riverstone & Keystone
- Compatible with all respective "islands plus" islands
- 72"W x 32"D x 37-3/4"H (OA) Footprint
- Poly Shims included for leveling

- A. 30" Viking Grill
- B. VGSB152T or VGIB151T
- C. AD1620T
- D. Optional VEWD163T

Model	Finish	Retail Price	Shipping wt. lb
<b>OMI07202VKSD</b>	Riverstone Dark	\$3,499	375
<b>OMI07202VKSL</b>	Riverstone Light	\$3,499	375
<b>OMI07202VKKD</b>	Keystone Dark	\$3,499	375
<b>OMI07202VKKL</b>	Keystone Light	\$3,499	375
<b>OMI07202VKUF</b>	Unfinished	\$2,000	230

S = Riverstone    K = Keystone    D = Uba Tuba    L = Giallo    UF = Unfinished

For Specific Use with Viking Outdoor Appliances  
 Island must be vented according to local codes.  
 Please refer to Limited 5 Year Warranty for details.



Outdoor Islands

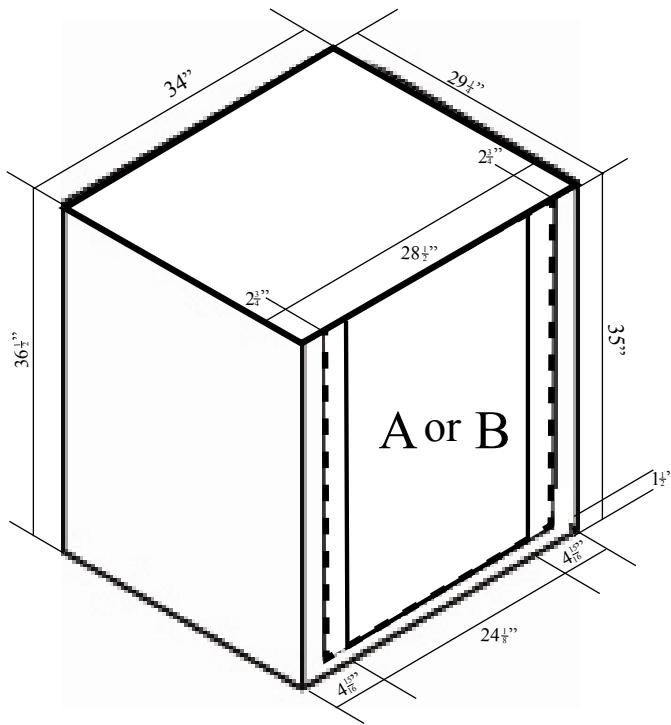

**36" Viking Island/Outdoor Solutions**

- Commercial-type construction, design and styling
- Island is constructed completely of Hardboard and DuraRock material over 20 gauge galvanized studs
- Interior cavity, seams, and corners completely finished
- Granite countertop / Options: Uba Tuba & Giallo
- Urethane resin veneer / Options: Riverstone & Keystone
- Compatible with all respective standard outdoor "islands"
- 36"W x 32"D x 37-3/4"H (OA) Footprint
- Poly Shims included for leveling

- A. VUAR143T or VURI140T (R/L) or VURD144T
- B. VUBD140T (R/L)

Field Requirement: MOUNTING OF DISPENSING TOWER AND FLANGED DRAIN PAN ARE NOT INCLUDED.

Model	Finish		Retail Price	Shipping wt. lb
<b>OMIP03601VKSD</b>	Riverstone Dark		\$1,999	350
<b>OMIP03601VKSL</b>	Riverstone Light		\$1,999	350
<b>OMIP03601VKKD</b>	Keystone Dark		\$1,999	350
<b>OMIP03601VKKL</b>	Keystone Light		\$1,999	350
<b>OMIP03601VKUF</b>	Unfinished		\$1,300	172

S = Riverstone    K = Keystone    D = Uba Tuba    L = Giallo    UF = Unfinished

For Specific Use with Viking Outdoor Appliances  
 Island must be vented according to local codes.  
 Please refer to Limited 5 Year Warranty for details.  
 Refrigerator legs are removed for proper installation.





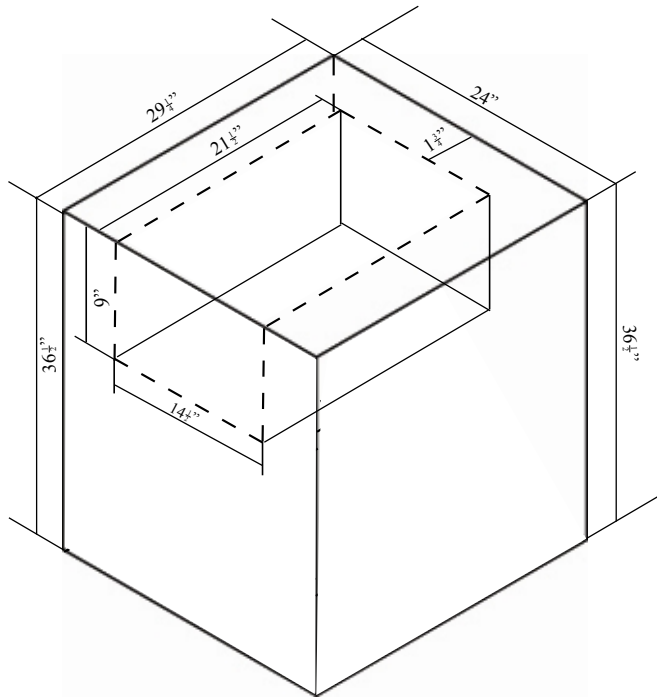

# 30'' Island

Outdoor Islands

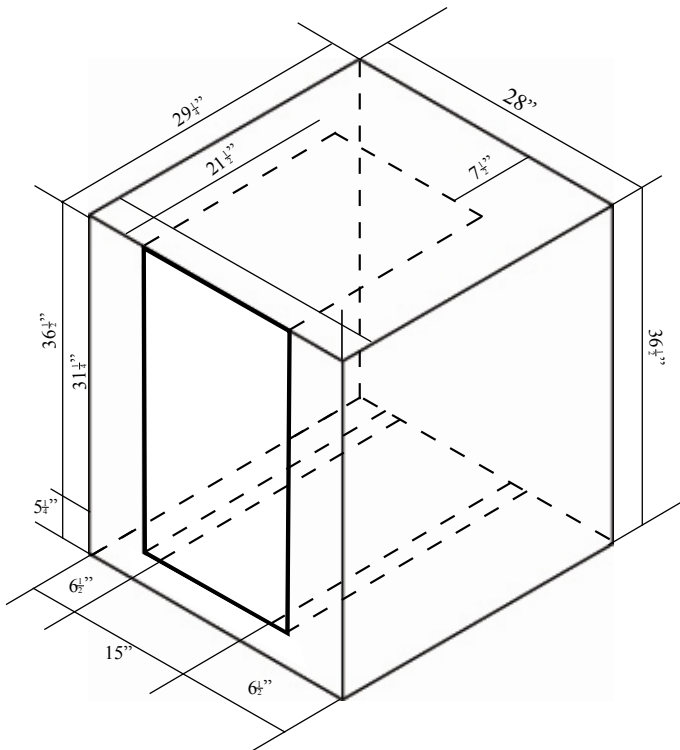

**30" Viking Island/Outdoor Solutions**

- Commercial-type construction, design and styling
- Island is constructed completely of Hardboard and DuraRock material over 20 gauge galvanized studs
- Granite countertop / Options: Uba Tuba & Giallo
- Urethane resin veneer / Options: Riverstone & Keystone
- Compatible with all respective standard outdoor "islands"
- 30"W x 31-7/8"D x 37-3/4"H (OA) Footprint
- Poly Shims included for leveling

A. VUIM150T

Model	Finish		Retail Price	Shipping wt. lb
<b>OMIP03001VKSD</b>	Riverstone Dark		\$1,999	350
<b>OMIP03001VKSL</b>	Riverstone Light		\$1,999	350
<b>OMIP03001VKKD</b>	Keystone Dark		\$1,999	350
<b>OMIP03001VKKL</b>	Keystone Light		\$1,999	350
<b>OMIP03001VKUF</b>	Unfinished		\$1,300	172

S = Riverstone    K = Keystone    D = Uba Tuba    L = Giallo    UF = Unfinished

For Specific Use with Viking Outdoor Appliances  
 Island must be vented according to local codes.  
 Please refer to Limited 5 Year Warranty for details.

Outdoor Islands

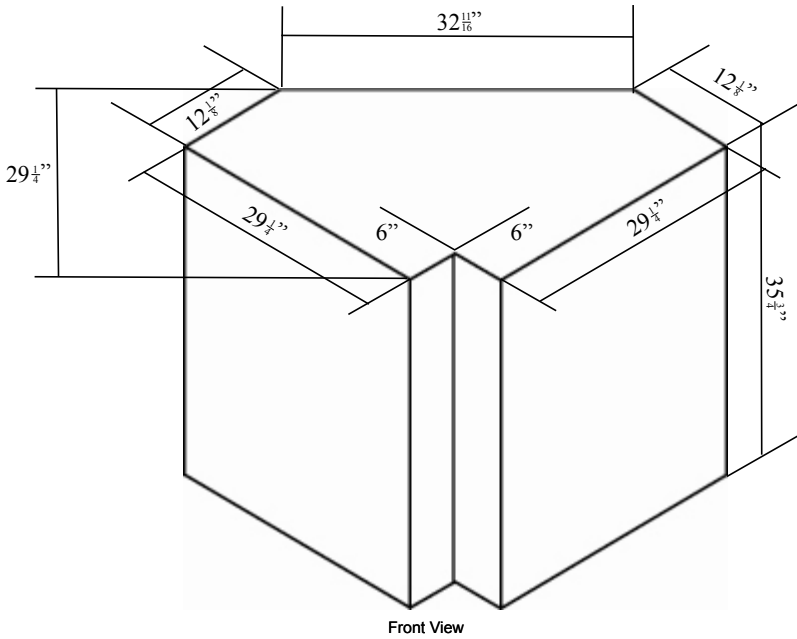

Universal 90° Corner/Outdoor Solutions

- Commercial-type construction, design and styling
- Island is constructed completely of Hardiboard and DuraRock material over 20 gauge galvanized studs
- Granite countertop / Options: Uba Tuba & Giallo
- Urethane resin veneer / Options: Riverstone & Keystone
- Compatible with all respective standard outdoor "islands"
- Isometric (OA) Footprint (see picture)
- Poly Shims included for leveling
- Gas or Electric access pass thru caps

Model	Finish	Retail Price	Shipping wt. lb
<b>OMIP09000VKSD</b>	Riverstone Dark	\$1,199	200
<b>OMIP09000VKSL</b>	Riverstone Light	\$1,199	200
<b>OMIP09000VKKD</b>	Keystone Dark	\$1,199	200
<b>OMIP09000VKKL</b>	Keystone Light	\$1,199	200
<b>OMIP09000VKUF</b>	Unfinished	\$900	98

S = Riverstone    K = Keystone    D = Uba Tuba    L = Giallo    UF = Unfinished

Please refer to Limited 5 Year Warranty for details.

Outdoor Islands

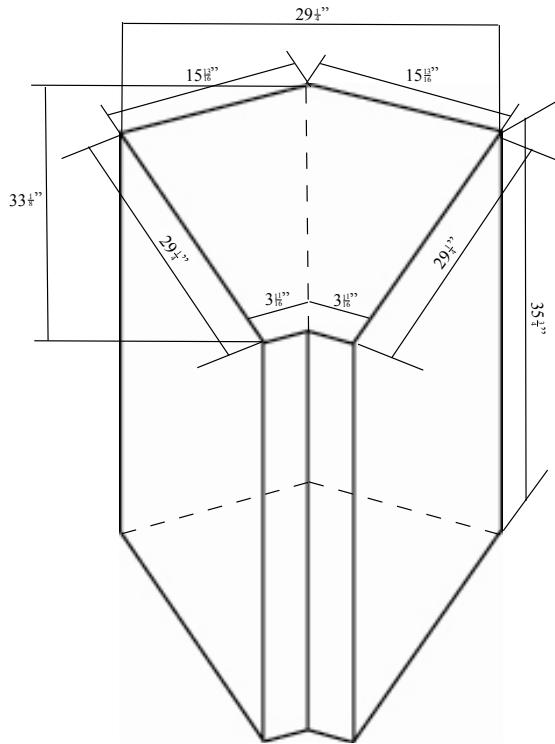

Universal 135° Corner/Outdoor Solutions

- Commercial-type construction, design and styling
- Island is constructed completely of Hardboard and DuraRock material over 20 gauge galvanized studs
- Granite countertop / Options: Uba Tuba & Giallo
- Urethane resin veneer / Options: Riverstone & Keystone
- Compatible with all respective standard outdoor "islands"
- Isometric (OA) Footprint (see picture)
- Poly Shims included for leveling
- Gas or Electric access pass thru caps

Model	Finish		Retail Price	Shipping wt. lb
<b>OMIP13500VKSD</b>	Riverstone Dark		\$1,199	200
<b>OMIP13500VKSL</b>	Riverstone Light		\$1,199	200
<b>OMIP13500VKKD</b>	Keystone Dark		\$1,199	200
<b>OMIP13500VKKL</b>	Keystone Light		\$1,199	200
<b>OMIP13500VKUF</b>	Unfinished		\$900	98

S = Riverstone    K = Keystone    D = Uba Tuba    L = Giallo    UF = Unfinished

Please refer to Limited 5 Year Warranty for details.





**Example:** OMI-084-01-VKSD



**Example:** OMI1084-02-VKKL